



**GROOVE E BEAT** MULTIFOOD FURNITURE COLLECTION



# Groove e Beat

---

## L'azienda 2-5

The company 2-5  
L'entreprise 2-5



## Le proposte di arredo ISA 6-7

ISA furnishings 6  
Les propositions  
de mobilier ISA 6  
Groove e Beat 7

## Groove 8-23



## Beat 24-37



## Referenze 38-39



References 38-39  
Références 38-39





# L'Azienda

IT

Siamo un'azienda tutta italiana, con le radici ben piantate in Umbria. Una storia caratterizzata da costanti innovazioni per progetti funzionali e di design in linea con l'evoluzione delle esigenze di moderni locali pubblici. Oggi ISA è una realtà industriale tra i leader mondiali nella refrigerazione professionale e dell'arredamento di locali pubblici, con oltre 600 collaboratori tra donne e uomini e un'area di 280.000 mq, di cui 62.000 mq dedicati agli impianti di produzione, alla logistica, agli uffici, allo show-room espositivo e al museo aziendale.

Con i suoi cinque marchi, ISA, COF, Tasselli, Hizone e Abaco, ISA distribuisce in 120 Paesi del mondo soluzioni tecnologiche refrigerate e arredamenti per bar, gelaterie, pasticcerie, ristoranti, gastronomie, laboratori alimentari, supermercati e grande distribuzione.

EN

**THE COMPANY.** We are an all-Italian company with our roots firmly planted in Umbria. A history characterised by constant innovations for functional and design projects in line with the evolving needs of modern public premises. Today, ISA is one of the world's leading industrial companies in the professional refrigeration and furnishing of public premises, with over 600 men and women employees and an area of 280,000 square metres, of which 62,000 m<sup>2</sup> dedicated to production facilities, logistics, offices, showroom and company museum.

With its five brands, ISA, COF, Tasselli, Hizone and Abaco, ISA distributes refrigerated technology solutions and furnishings for bars, ice cream parlours, pastry shops, restaurants, delicatessens, food processors, supermarkets and supermarkets in 120 countries around the world.

FR

**L'ENTREPRISE.** Nous sommes une entreprise entièrement italienne, dont les racines sont bien ancrées en Ombrie. Une histoire caractérisée par des innovations constantes pour des projets fonctionnels et en ligne avec les besoins évolutifs des locaux modernes locaux publics. ISA est aujourd'hui une réalité industrielle parmi les leaders leaders mondiaux de la réfrigération professionnelle et de l'ameublement des locaux publics, avec plus de 600 employés hommes et femmes et une superficie de 280.000 mètres carrés, dont 62 000 m<sup>2</sup> dédiés aux installations de production, à la logistique logistique, bureaux, showroom et musée d'entreprise. musée de l'entreprise.

Avec ses cinq marques, ISA, COF, Tasselli, Hizone et Abaco, ISA distribue dans 120 pays du monde des solutions technologiques et d'ameublement pour les bars, glaciers, pâtisseries, restaurants, épiceries supermarchés et grande distribution.

# Business unit

IT

## GELATO / PASTRY

ISA propone un'ampia articolata gamma di soluzioni Hi-end per la conservazione e l'esposizione di gelato e pasticceria. Una proposta che si completa con armadi e tavoli refrigerati da laboratorio, dedicati ai professionisti gelatieri, pasticceri e chef.

## FOOD / BEVERAGE

ISA ha sviluppato un'area dedicata alle vetrine refrigerate promozionali e alle avancasse. Soluzioni capaci di offrire un alto standard di conservazione e la migliore esposizione di prodotti surgelati e freschi quali, gelati, snack, bevande, vini, ecc.

## MARKET / SUPERMARKET / GDO

ISA e il suo brand Tasselli propongono attrezzature refrigerate per la piccola, media e Grande Distribuzione Organizzata: espositori murali e semi-murali, banchi frigo tradizionali e isole espositive e promozionali, combinati e retro-banchi, disponibili in versione plug-in o da remoto.

EN

## GELATO / PASTRY

ISA offers a wide range of high-end solutions for the storage and display of gelato and pastries. A catalogue that includes refrigerated cabinets and counters dedicated to the world of gelato artisans, pastry professionals and chefs.

## FOOD & BEVERAGE

ISA has developed an area focused on promotional refrigerated display cabinets and POP displays. Solutions offering a high standard of preservation and the best possible display of fresh and frozen products such as gelato, snacks, drinks, etc.

## MARKET/SUPERMARKET/RETAIL

ISA and its Tasselli brand offer refrigerated equipment for small, medium and large-scale retail: multidecks and semi-verticals, traditional refrigerated counters and display and promotional islands, combination displays and back counters, available in plug-in or remote versions.

## LAB - FOOD PRODUCTION EQUIPMENT

Lab is ISA's range of professional refrigerated equipment dedicated to the production area: the place where the creative art of pastry making, cooking and gelato production takes place.

## SEMI-FINISHED TECHNOLOGICAL PRODUCTS

Abaco is the ISA brand dedicated to technological systems and modular solutions with different types of refrigeration for use in any type of venue (bars, pastry shops, gelato parlours, delicatessens, cafeterias and self-service restaurants).

## SHOPFITTING

ISA completes its range of refrigeration technologies with furnishings for foodservice venues. Thanks to a rich selection of materials, ISA's furniture collections offer a wide range of customisations for use in any context and setting.

## LAB - ATTREZZATURE LABORATORI FOOD

Lab è la gamma prodotti ISA che propone le attrezzature refrigerate professionali dedicate al laboratorio: il luogo in cui nasce l'arte creativa della pasticceria, della cucina e della gelateria.

## SEMILAVORATI TECNOLOGICI

Abaco, è il brand di ISA dedicato a sistemi tecnologici e soluzioni modulari con diverse tipologie di refrigerazione, per realizzare qualsiasi progetto di locale (bar, pasticcerie, gelaterie, gastronomie, tavole calde e self-service).

## ARREDAMENTO / CONTRACT

ISA offre soluzioni tecnologiche per il freddo e proposte di arredo personalizzate per locali pubblici: collezioni, arredamento su misura, contract, format. Grazie ad una ricca materioteca le collezioni di arredo ISA offrono un ampio range di personalizzazione per integrarsi in qualsiasi contesto e ambientazione.

FR

## CRÈME GLACÉE / PÂTISSERIE

ISA propose une vaste gamme de solutions haut de gamme pour le stockage et la présentation des glaces et des pâtisseries. Une proposition qui est complétée par des armoires réfrigérées et des tables de laboratoire, dédiées au monde des glaciers professionnels, des pâtisseries et des chefs cuisiniers.

## ALIMENTATION ET BOISSONS

ISA a créé un espace consacré aux armoires frigorifiques et aux vitrines promotionnelles. Des solutions capables d'offrir un haut niveau de conservation et la meilleure présentation possible de produits surgelés et frais tels que glaces, snacks, boissons, etc.

## MARCHÉ/SUPERMARCHÉ/GRANDES SURFACES

ISA et sa marque Tasselli proposent des équipements réfrigérés pour la petite, moyenne et grande distribution : présentoirs muraux et semi-muraux, comptoirs réfrigérés traditionnels et îlots d'exposition et de promotion, unités combinées, arrière-comptoirs, disponible en version enfichable ou à distance.

## LAB - ÉQUIPEMENT DE LABORATOIRE ALIMENTAIRE

Lab est la gamme de produits ISA qui propose des équipements réfrigérés professionnels dédiés au laboratoire : le lieu où naît l'art créatif de la pâtisserie, de la cuisine et de la production de glaces.

## PRODUITS SEMI-FINIS TECHNOLOGIQUES

Abaco est la marque ISA dédiée aux systèmes technologiques et aux solutions modulaires avec différents types de réfrigération, afin de créer tout type de projet d'établissement (bars, pâtisseries, glaciers, épiceries fines, cafétérias et restaurants libre-service).

## AMEUBLEMENT

ISA complète son offre de technologies frigorifiques avec des propositions d'ameublement pour les locaux publics. Grâce à une riche bibliothèque de matériaux, les collections d'ameublement d'ISA offrent un large éventail de possibilités de personnalisation pour s'intégrer dans n'importe quel contexte et n'importe quelle ambiance.

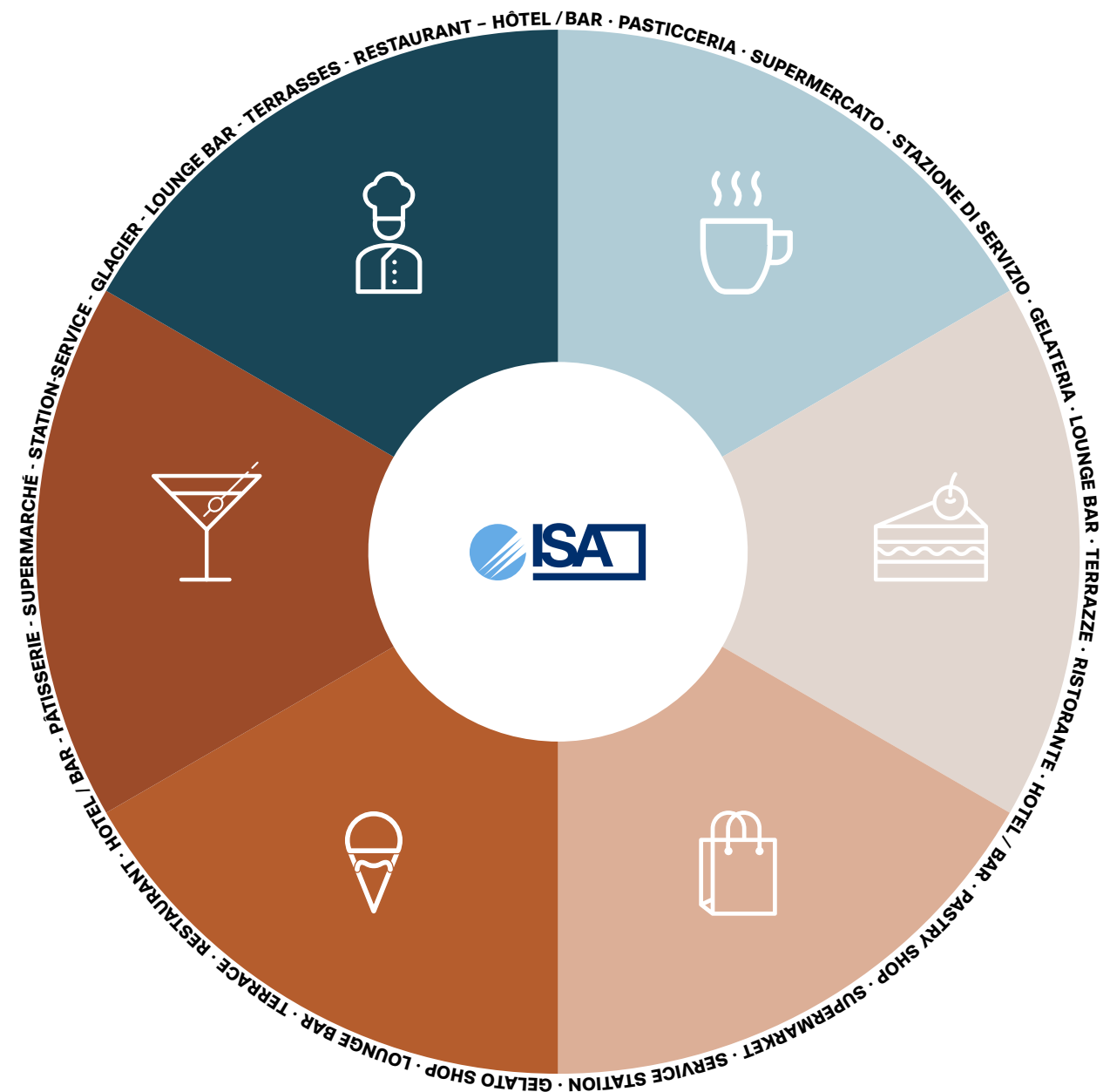

# Le proposte di arredo ISA

## Groove e Beat

### IT

Groove e Beat sono collezioni d'arredo multifood che vanno ad arricchire la proposta ISA che, da sempre, si distingue per saper tradurre, in una logica industriale, la vocazione e le abilità artigianali che caratterizzano ogni progetto made in ISA. Si tratta di linee versatili che possono dialogare tra loro, per dar vita ad un layout da contestualizzare alle più diverse ambientazioni stilistiche dei locali pubblici.

Che si tratti di uno stile industrial o di uno stile scandinavo, vintage o di qualsiasi altro stile, il tema della personalizzazione è un valore sia per Groove che per Beat. Grazie ad una ricca materioteca ISA propone, per le sue linee d'arredo, una ampia gamma di materiali e finiture per rendere l'idea progettuale unica e personalizzabile in linea con il concept dello spazio. Entrambe le proposte coniugano una spiccata evidenza espositiva a funzioni di refrigerazione professionale, dagli aspetti dedicati all'ergonomia del layout per migliorare il comfort per gli operatori, alla ricerca di un design accogliente e di forte appeal per il pubblico.

### EN

Groove and Beat are multifood furnishing collections that have been added to an ISA product range that for over 60 years has distinguished itself for being able to translate the practicality and craftsmanship that characterise every project made by ISA into an industrial logic. They are versatile lines that can dialogue with each other to create a layout that can blend into the most diverse stylistic settings of foodservice businesses.

Whether the current look is industrial or Scandinavian, vintage or any other style, personalisation is a key value for both Groove and Beat. Thanks to a rich selection of materials, ISA offers a wide range of looks and finishes for its furniture lines to make your design unique and personalised while remaining in sync with the space's concept. Both lines combine a strong emphasis on maximising your products' visibility with professional refrigeration functions, from aspects dedicated to the ergonomics of the layout to improve your staff's comfort to research into a welcoming design with a strong appeal to the public.

### FR

Groove et Beat sont des collections d'ameublement multifood qui enrichissent la proposition ISA qui, depuis plus de 60 ans, se distingue par sa capacité à traduire en logique industrielle la vocation et le savoir-faire qui caractérisent chaque projet réalisé chez ISA. Il s'agit de lignes polyvalentes qui peuvent dialoguer entre elles pour créer un aménagement qui peut être contextualisé dans les ambiances stylistiques les plus diverses des lieux publics.

Qu'il soit industriel ou scandinave, vintage ou autre, le thème de la personnalisation est une valeur pour Groove et Beat. Grâce à une riche bibliothèque de matériaux, ISA offre une large gamme de matériaux et de finitions pour ses lignes de mobilier afin de rendre l'idée de conception unique et personnalisable en fonction du concept de l'espace. Les deux propositions combinent une forte évidence d'exposition avec des fonctions de réfrigération professionnelle, des aspects dédiés à l'ergonomie de l'agencement pour améliorer le confort des opérateurs, à la recherche d'un design accueillant avec un fort attrait pour le public.



IT

Groove è la collezione di arredo ISA per locali pubblici d'avanguardia, che prende forma da linee semplici ed essenziali, tipiche dello stile minimal e industriale. Si contraddistingue da un forte impatto estetico e si rivolge ad un mercato esigente e sensibile ad una forte spinta verso un design di tendenza. La sua presenza, all'interno del contesto, si esprime nella semplicità razionale di linee geometriche e dall'alternanza di volumi monolitici e spezzati.

# Groove

EN

Groove is the ISA furnishing collection for cutting-edge foodservice businesses, with simple, essential lines typical of a minimalist industrial style. It has a bold look and was developed for a discerning market that is sensitive to a strong tendency towards trendy design. Its presence within the venue is expressed through the rational simplicity of its geometric lines and the alternation of whole and detached volumes.

FR

Groove est la collection de mobilier ISA pour les lieux publics d'avant-garde, qui prend forme à partir de lignes simples et essentielles, typiques du style minimal et industriel. Elle se caractérise par un fort impact esthétique et s'adresse à un marché exigeant, sensible à une forte tendance au design branché. Sa présence dans le contexte s'exprime par la simplicité rationnelle des lignes géométriques et l'alternance de volumes monolithiques et composés.











- (1) Pannello frontale Beton Cemento Scuro
- (2) Pannello inferiore Texture Bronzo
- (3) Piani Compact Marquina
- (4) Zoccolo Deep Black Opaco
- (5) Ripiani retro Solid Tortora
- (6) Ripiani retro Metacrilato Fumè
- (7) Strutture retro Wallbar, Antracite RAL 7021

- (1) Front panel Beton Cemento Scuro
- (2) Lower panel Texture Bronzo
- (3) Shelves Compact Marquina
- (4) Baseboard Deep Black Opaco
- (5) Back shelves Solid Tortora
- (6) Back shelves Metacrilato Fumè
- (7) Back structure Wallbar, Antracite RAL 7021

- (1) Panneau avant Beton Cemento Scuro
- (2) Panneau inférieur Texture Bronzo
- (3) Plateau Compact Marquina
- (4) Plinthe Deep Black Opaco
- (5) Tablettes arrière Solid Tortora
- (6) Tablettes arrière Metacrilato Fumè
- (7) Structure arrière Wallbar, Antracite RAL 7021









- (1) Pannello frontale Solid Tortora
- (2) Pannello inferiore Solid Noce 09
- (3) Piani Compact Nuvolento
- (4) Zoccolo Deep Black Opaco
- (5) Ripiani retro Solid Noce 09
- (6) Ripiani retro Solid Tortora
- (7) Strutture retro Wallbar, Antracite RAL 7021

- (1) Front panel Solid Tortora
- (2) Lower panel Solid Noce 09
- (3) Shelves Compact Nuvolento
- (4) Baseboard Deep Black Opaco
- (5) Back shelves Solid Noce 09
- (6) Back shelves Solid Tortora
- (7) Back structure Wallbar, Antracite RAL 7021

- (1) Panneau avant Solid Tortora
- (2) Panneau inférieur Solid Noce 09
- (3) Plateau Compact Nuvolento
- (4) Plinthe Deep Black Opaco
- (5) Tablettes arrière Solid Noce 09
- (6) Tablettes arrière Solid Tortora
- (7) Structure arrière Wallbar, Antracite RAL 7021





# Groove

## COLORI DISPONIBILI / AVAILABLE COLOURS / COULEURS DISPONIBLES

### Solid

Pannello nobilitato con finitura opaca / Melamine panel with matt finish / Panneau mélamine finition mate



### Beton

Pannello placcato con vera malta cementizia / Laminated panel with real cement mortar / Panneau laminé avec mortier de ciment



### Texture

Pannello placcato in ABS+PMMA / Laminated panel in ABS+PMMA / Panneau laminé ABS+PMMA



### Compact

HPL / HPL / HPL

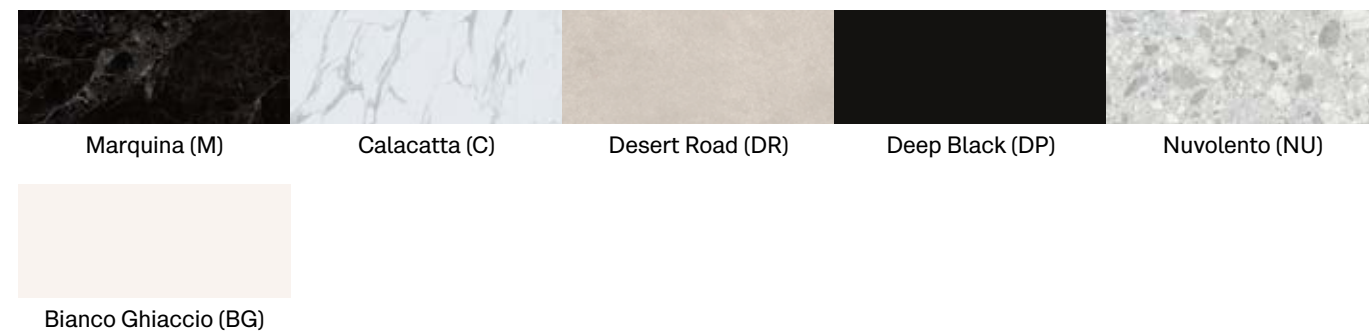

### Gres

Gres Porcellanato / Porcelain Stoneware / Grès Cérame



### Mirror

Pannello placcato in PMMA  
Laminated panel in PMMA  
Panneau laminé en PMMA

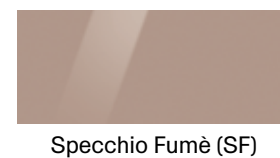

## GROOVE 230

Combinazione con pannello frontale MAXI  
Combination with MAXI front panel  
Combinaison avec panneau avant MAXI

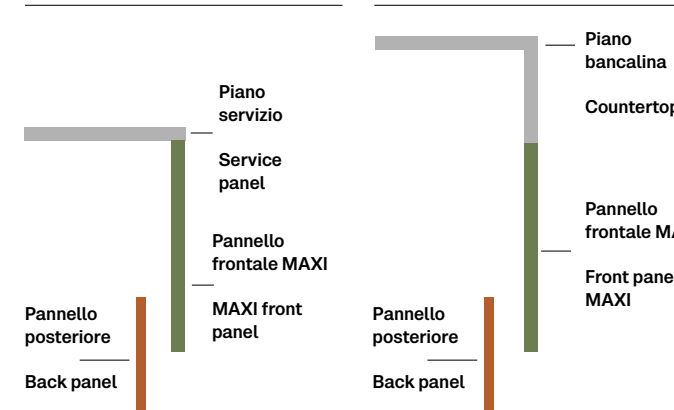

## GROOVE 540

Combinazione con pannello frontale SLIM  
Combination with SLIM front panel  
Combinaison avec panneau avant SLIM

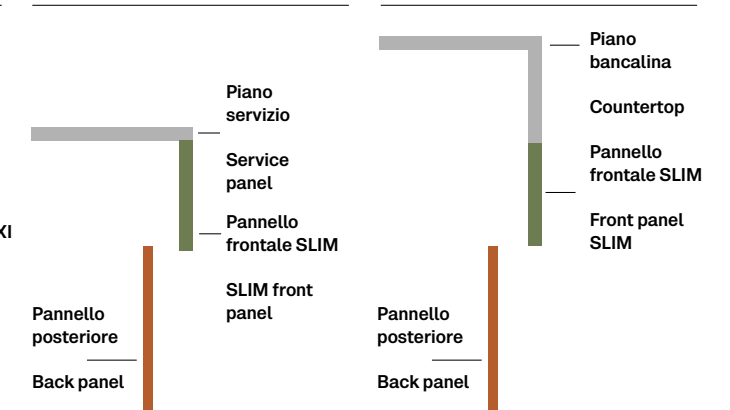

# Personalizzazione / Customisation / Personnalisation

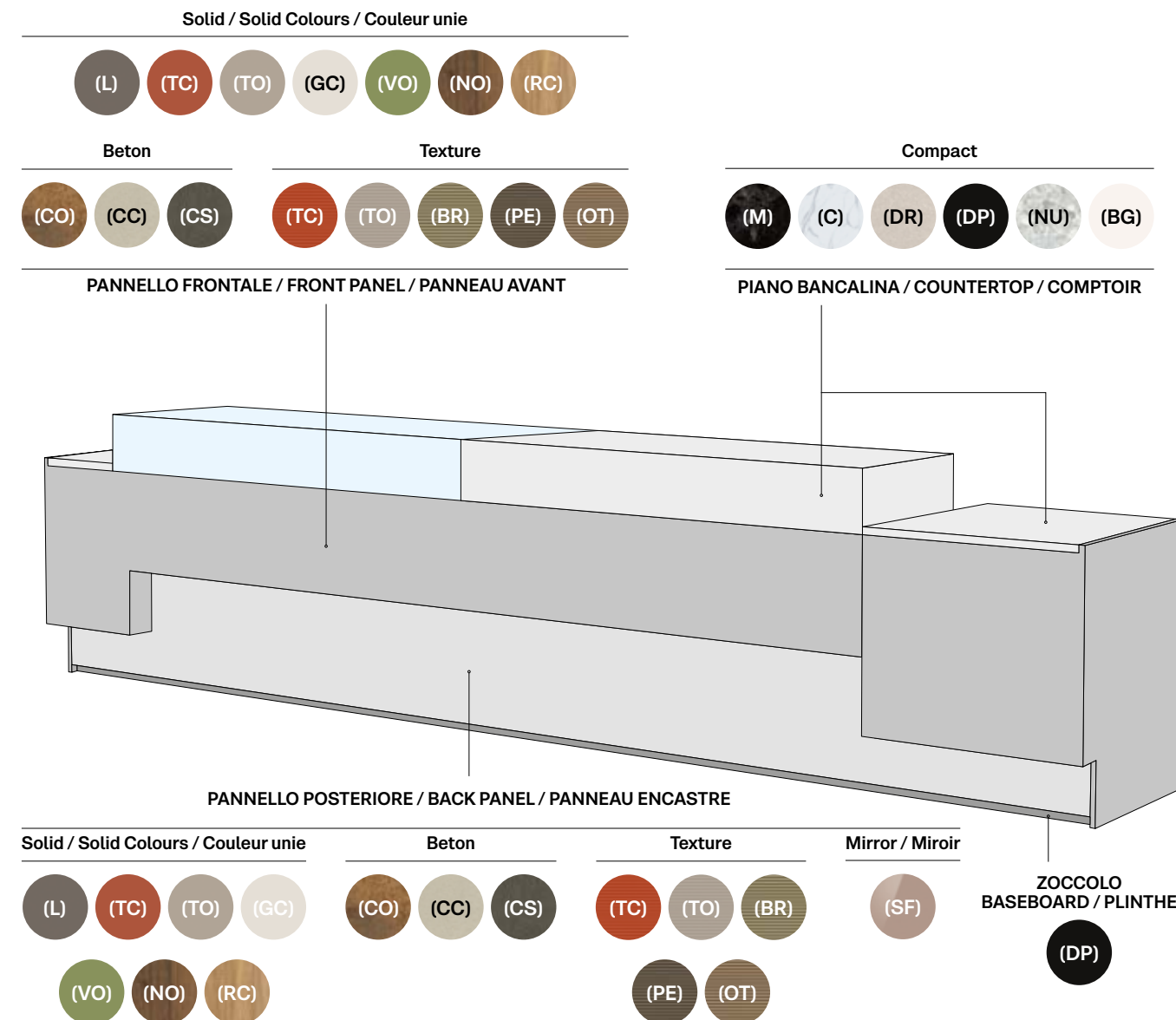

# Groove 230

SPECIFICHE TECNICHE / TECHNICAL SPECIFICATIONS / CARACTERISTIQUES TECHNIQUES

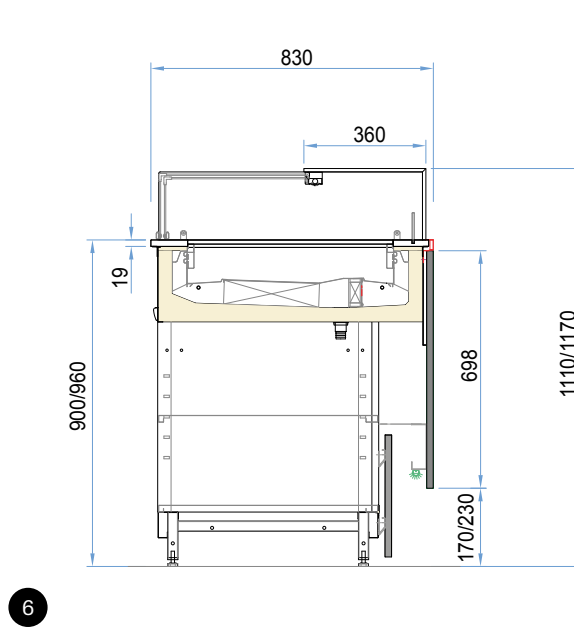
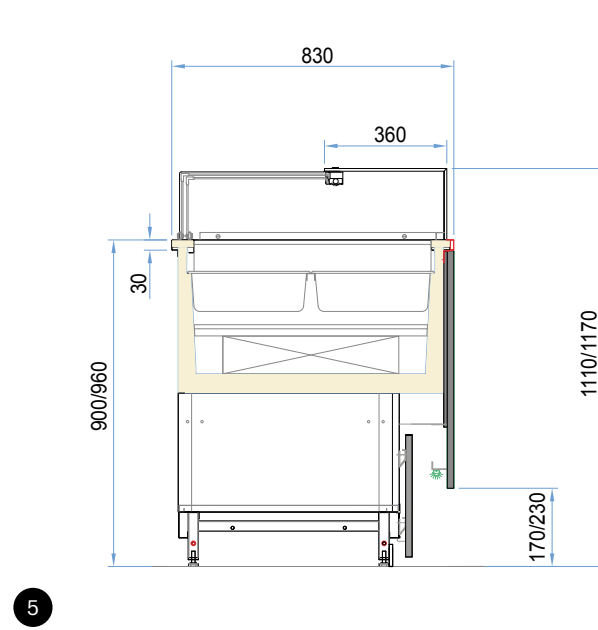
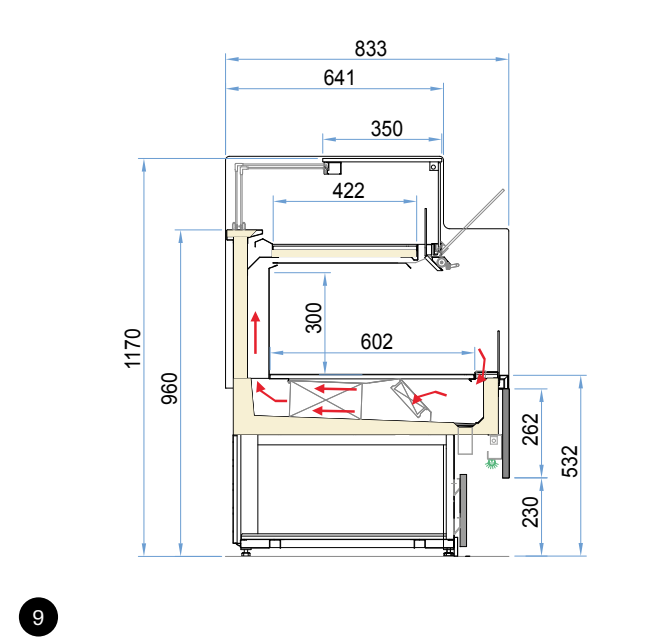
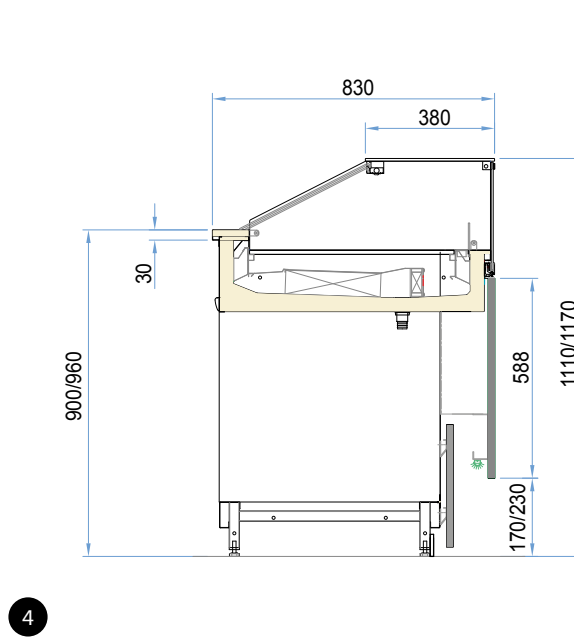
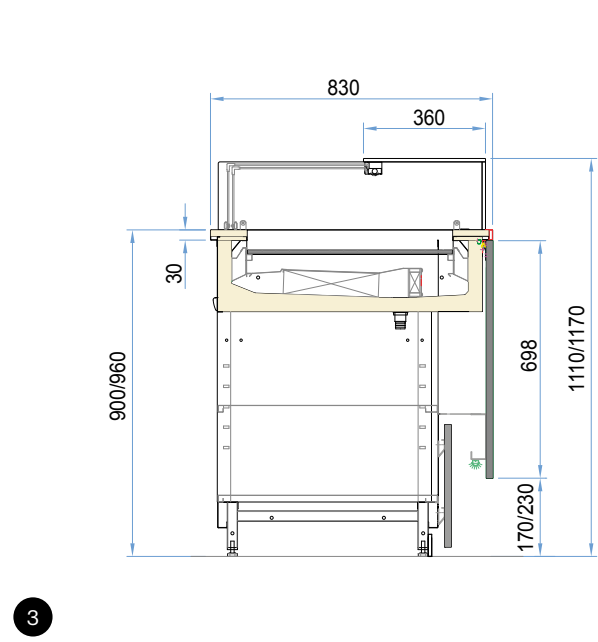
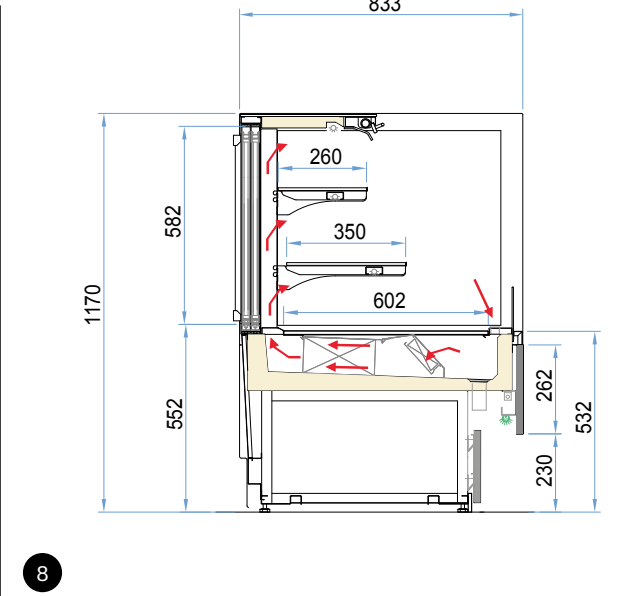
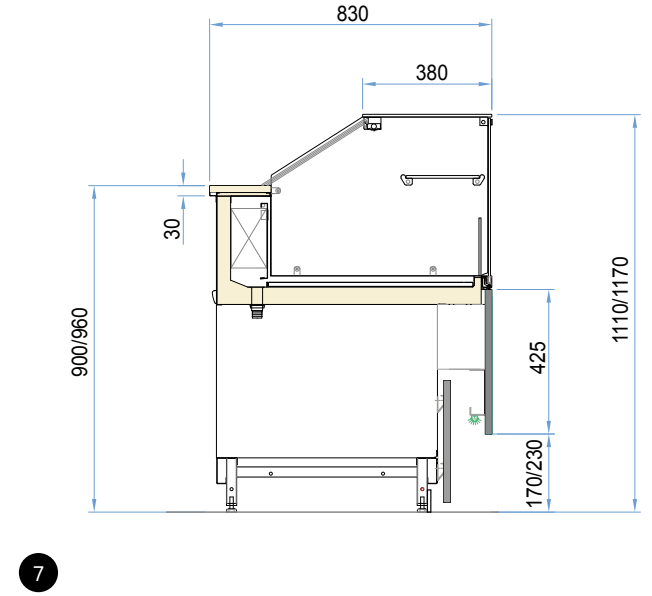
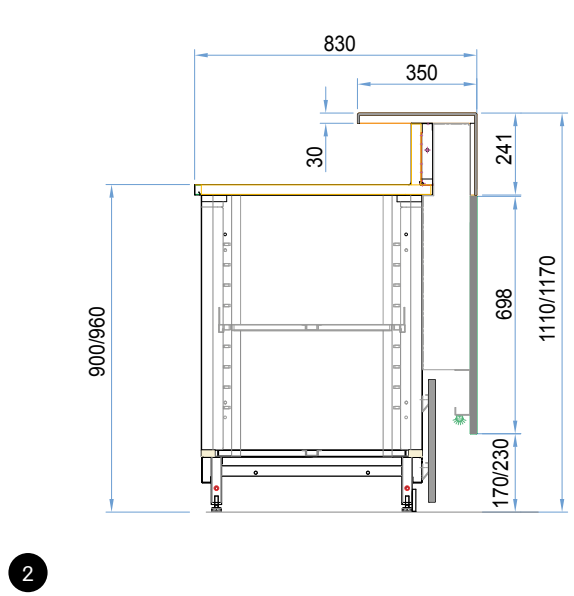
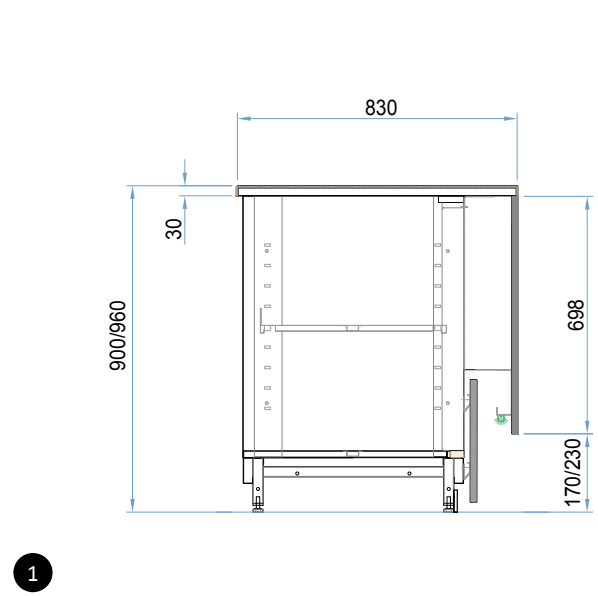

## SEZIONI GROOVE 230 / GROOVE 230 SECTIONS / SECTIONS GROOVE 230 : H 160 / 100

Modello / Model / Modèle	Lunghezza modulo / Module length / Longueur module
1 Cassa Servizio	50 / 62.5 / 75 / 100 / 125 / 150 / 175 / 200 / 225 / 250 / 275 / 300 / 325 / 350 / 375 / 400
2 Banco Bar MO	50 / 62.5 / 75 / 100 / 125 / 150 / 175 / 200 / 225 / 250 / 275 / 300 / 325 / 350 / 375 / 400
3 Drop-in	100 / 125 / 150 / 175 / 200 / TDX 150 / TSX 150
4 Vetrina - Esposizione Alta	100 / 125 / 150 / 175 / 200 / TDX 150 / TSX 150
5 Vetrina - Gelati DLT	125
6 Vetrina - FLAT	100 / 125 / 150 / 175 / 200 / TDX 150 / TSX 150
7 Vetrina - Esposizione Bassa	100 / 125 / 150 / 175 / 200 / TDX 150 / TSX 150
8 Vetrina - Metro	100 / 130 / 150
9 Vetrina - Combi	100 / 130 / 150



# Groove 540

SPECIFICHE TECNICHE / TECHNICAL SPECIFICATIONS / CARACTERISTIQUES TECHNIQUES

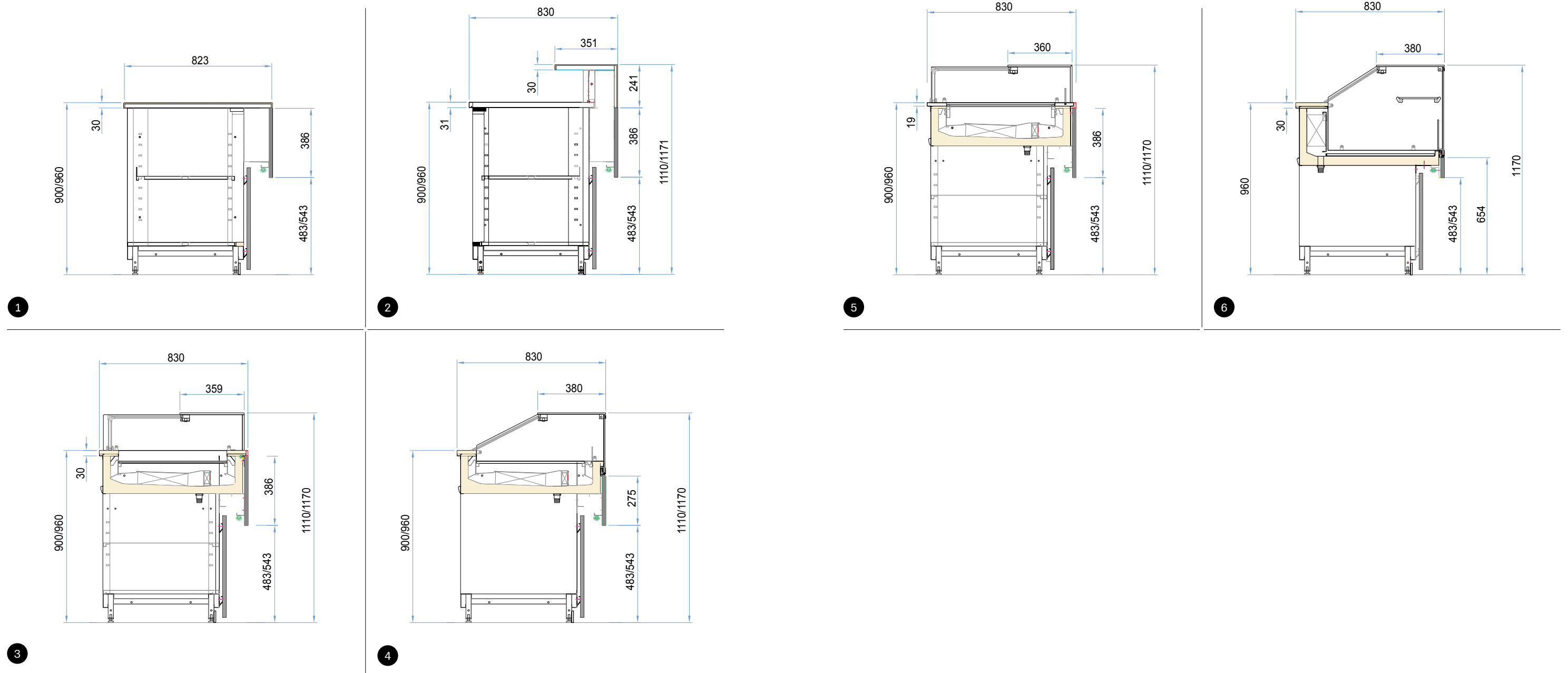

## SEZIONI GROOVE 540 / GROOVE 540 SECTIONS / SECTIONS GROOVE 540 : H 160 / 100

Modello / Model / Modèle	Lunghezza modulo / Module length / Longueur module
1 Cassa Servizio	50 / 62.5 / 75 / 100 / 125 / 150 / 175 / 200 / 225 / 250 / 275 / 300 / 325 / 350 / 375 / 400
2 Banco Bar MO	50 / 62.5 / 75 / 100 / 125 / 150 / 175 / 200 / 225 / 250 / 275 / 300 / 325 / 350 / 375 / 400
3 Drop-in	100 / 125 / 150 / 175 / 200 / TDX 150 / TSX 150
4 Vetrina - Esposizione Alta	100 / 125 / 150 / 175 / 200 / TDX 150 / TSX 150
5 Vetrina - FLAT	100 / 125 / 150 / 175 / 200 / TDX 150 / TSX 150
6 Vetrina - Esposizione Bassa	100 / 125 / 150 / 175 / 200 / TDX 150 / TSX 150

IT

Il progetto Beat è stata l'occasione per riflettere su un design ispirato alla semplicità, a partire da un'attenta ricerca di forme lineari e pulite. Caratterizzato da linee squadrate Beat è una linea di arredo che definisce visivamente lo spazio del locale grazie ad una pannellatura frontale lineare e discreta che accompagna lo sguardo in maniera armoniosa. Beat è la linea d'arredo che va oltre le mode del tempo, frutto di design, studi ergonomici ed estetici, uniti all'esperienza di oltre 60 anni di storia che ISA rappresenta. La sua estetica è versatile e personalizzabile grazie ad una materioteca che propone un'ampia gamma di materiali, cromie e finiture che riflettono le moderne tendenze del living contemporaneo.

# Beat

EN

The Beat project was an opportunity to reflect on a design inspired by simplicity, starting with an attentive study of clean, linear forms. Characterised by its squared lines, Beat is a range that visually defines the space of the room thanks to a discreet, linear front panelling that harmoniously accompanies the eye's gaze. Beat is the line of furnishings that goes beyond the fashion of the day, the result of design, ergonomic and aesthetic studies, combined with an experience of more than 60 years of ISA history. Its aesthetics are versatile and customisable thanks to a selection of materials that offers a wide range of looks, colours and finishes reflecting modern trends of contemporary living.

FR

Le projet Beat a été l'occasion de réfléchir à un design inspiré par la simplicité, à partir d'une recherche minutieuse de formes linéaires et épurées. Caractérisée par des lignes carrées, Beat est une ligne d'ameublement qui définit visuellement l'espace de la pièce grâce à une façade linéaire et discrète qui accompagne le regard de manière harmonieuse. Beat est la ligne d'ameublement qui va au-delà des modes du temps, le résultat d'études de design, d'ergonomie et d'esthétique, combinées à l'expérience de plus de 60 ans d'histoire que représente ISA. Son esthétique est polyvalente et personnalisable grâce à une bibliothèque de matériaux offrant une large gamme de matériaux, de couleurs et de finitions qui reflètent les tendances modernes de l'habitat contemporain.











- (1) Pannello frontale Solid Terracotta
- (2) Gola Solid Tortora
- (3) Piani Compact Deep Black
- (4) Zoccolo Compact Deep Black
- (5) Ripiani retro Solid Rovere 18
- (6) Ripiani retro Solid Tortora
- (7) Strutture retro wallbar, Antracite RAL 7021

- (1) Front panel Solid Terracotta
- (2) Recess Solid Tortora
- (3) Shelves Compact Deep Black
- (4) Baseboard Compact Deep Black
- (5) Back shelves Solid Rovere 18
- (6) Back shelves Solid Tortora
- (7) Back structure wallbar, Antracite RAL 7021



- (1) Panneau avant Solid Terracotta
- (2) Panneau encastré Solid Tortora
- (3) Plateau Compact Deep Black
- (4) Plinthe Compact Deep Black
- (5) Tablettes arrière Solid Rovere 18
- (6) Tablettes arrière Solid Tortora
- (7) Structures arrière wallbar, Antracite RAL 7021









- (1) Pannello frontale Solid Grigio Chiaro
- (2) Gola Solid Tortora
- (3) Piani Compact Deep Black
- (4) Zoccolo Compact Deep Black
- (5) Ripiani retro Solid Rovere 18
- (6) Ripiani retro Metacrilato Fumè
- (7) Strutture retro wallbar, Antracite RAL 7021

- (1) Front panel Solid Grigio Chiaro
- (2) Recess Solid Tortora
- (3) Shelves Compact Deep Black
- (4) Baseboard Compact Deep Black
- (5) Back shelves Solid Rovere 18
- (6) Back shelves Metacrilato Fumè
- (7) Back structure wallbar, Antracite RAL 7021

- (1) Panneau avant Solid Grigio Chiaro
- (2) Panneau encastré Solid Tortora
- (3) Plateau Compact Deep Black
- (4) Plinthe Compact Deep Black
- (5) Tablettes arrière Solid Rovere 18
- (6) Tablettes arrière Metacrilato Fumè
- (7) Structures arrière wallbar, Antracite RAL 7021





# Beat

## COLORI DISPONIBILI / AVAILABLE COLOURS / COULEURS DISPONIBLES

### Solid

Pannello nobilitato con finitura opaca / Melamine panel with matt finish / Panneau mélamine finition mate



### Beton

Pannello placcato con vera malta cementizia / Laminated panel with real cement mortar / Panneau laminé avec mortier de ciment



### Texture

Pannello placcato in ABS+PMMA / Laminated panel in ABS+PMMA / Panneau laminé ABS+PMMA



### Compact

HPL / HPL / HPL

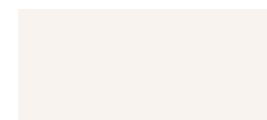

### Gres

Gres Porcellanato / Porcelain Stoneware / Grès Cérame



### Mirror

Pannello placcato in PMMA  
Laminated panel in PMMA  
Panneau laminé en PMMA

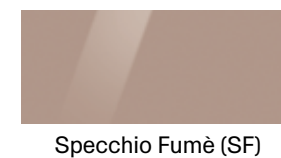

### BEAT G2

Pannellatura doppia gola  
Double recess  
Panneau double encastrement

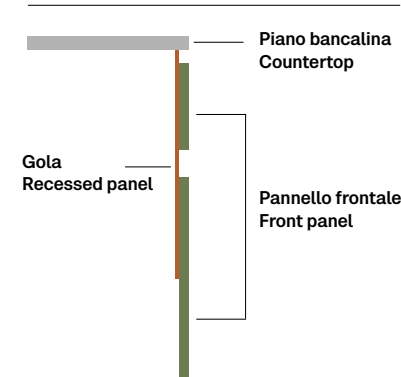

### BEAT GH

Pannellatura gola singola  
Single recess  
Panneau encastré individuel

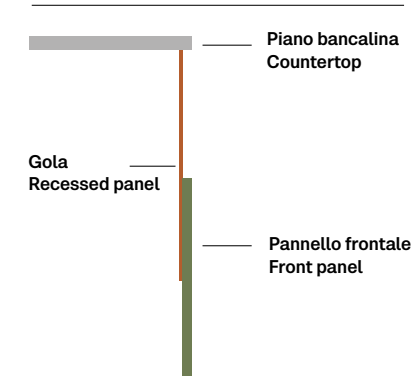

### BEAT M0

Bancalina monolitica  
One-piece countertop  
Banc en bloc

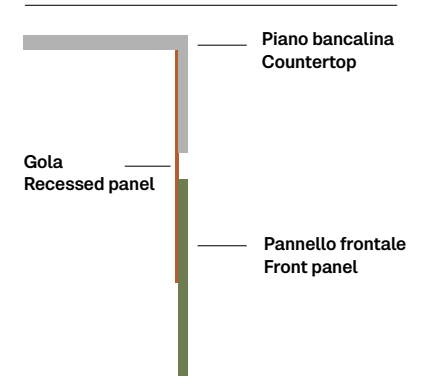

## Personalizzazione / Customisation / Personnalisation

**Solid / Solid Colours / Couleur unie**    **Mirror / Miroir**

(L) (TC) (TO) (GC) (VO)    (SF)

(NO) (RC)

**Compact**

(M) (C) (DR) (DP) (NU) (BG)

**PANNELLO FRONTALE / FRONT PANEL / PANNEAU AVANT**    **PIANO BANCALINA / COUNTERTOP / COMPTOIR**

**PANNELLO POSTERIORE / BACK PANEL / PANNEAU ENCASTRE**

**Solid / Solid Colors / Couleur unie**    **Beton**    **Texture**

(L) (TC) (TO) (GC) (VO)    (CO) (CC) (CS)    (TC) (TO) (BR)

(NO) (RC)    (PE) (OT)

**ZOCCOLO BASEBOARD / PLINTHE**

(DP)

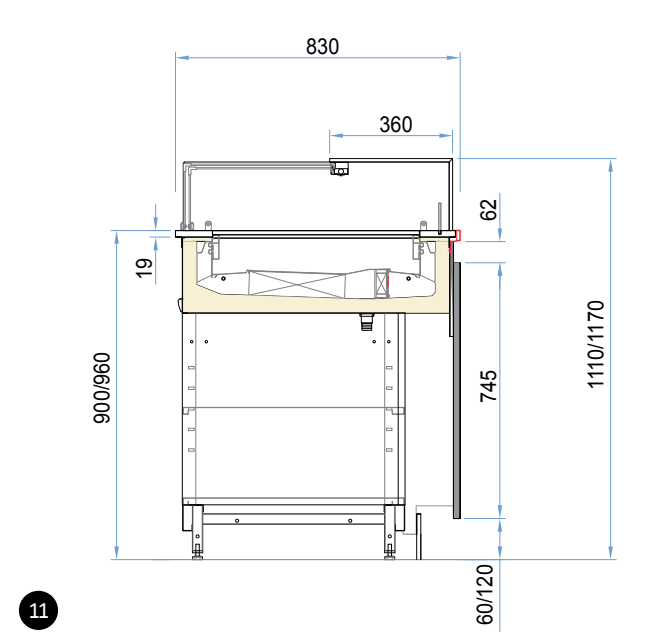
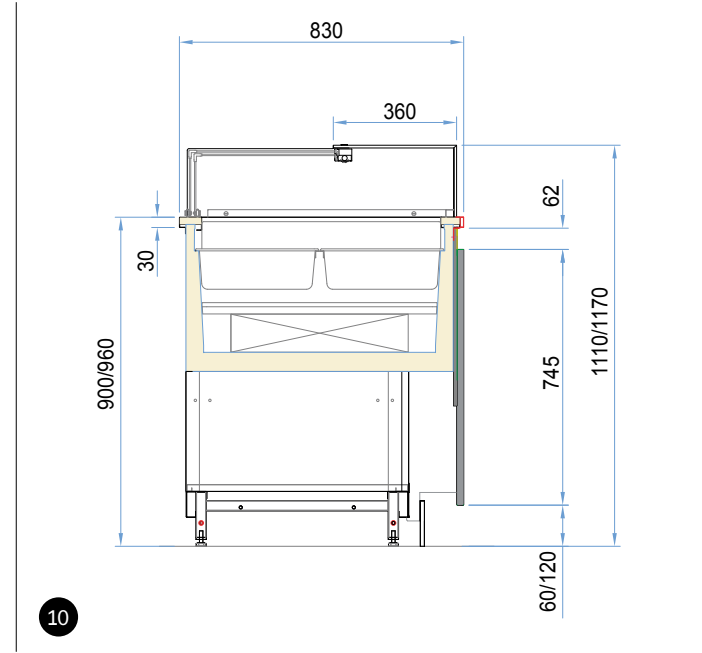
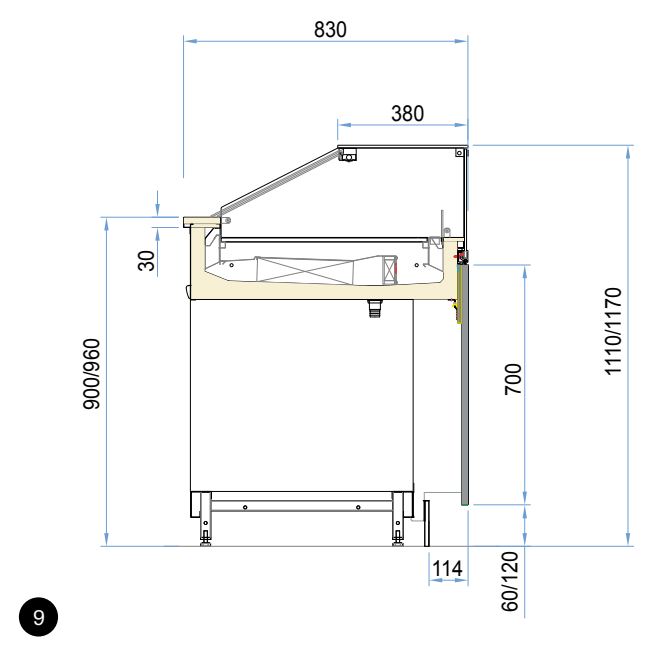
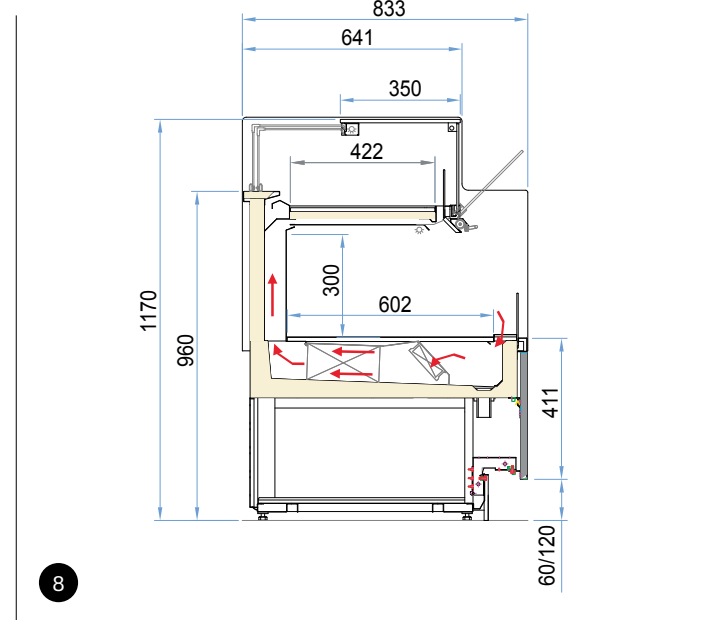
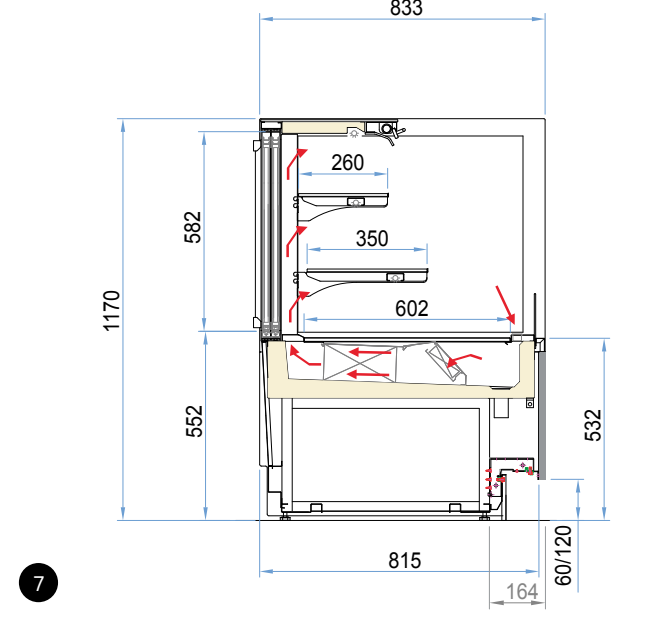
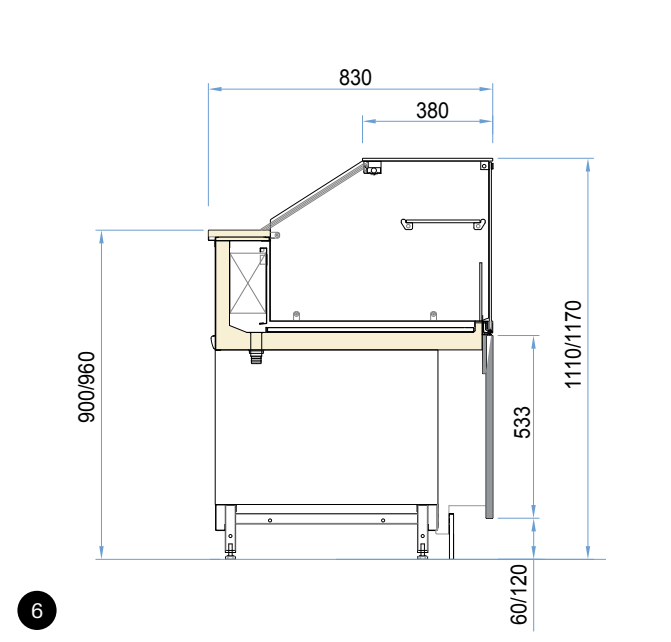
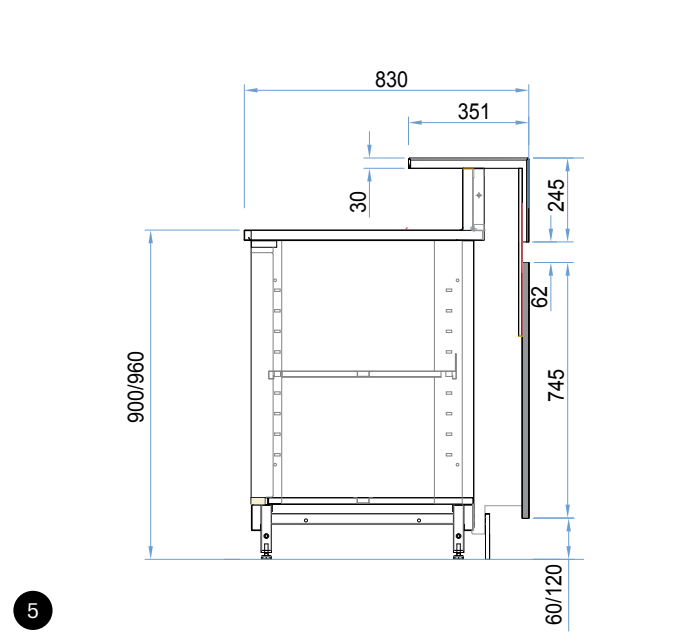
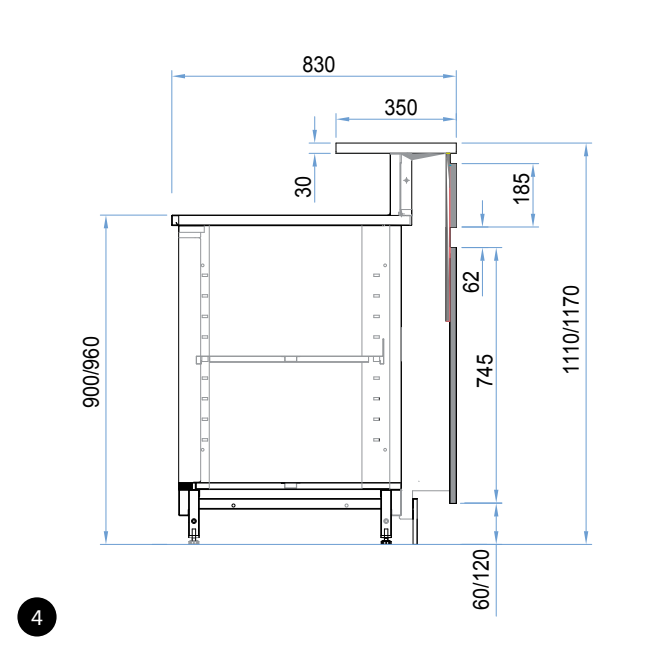
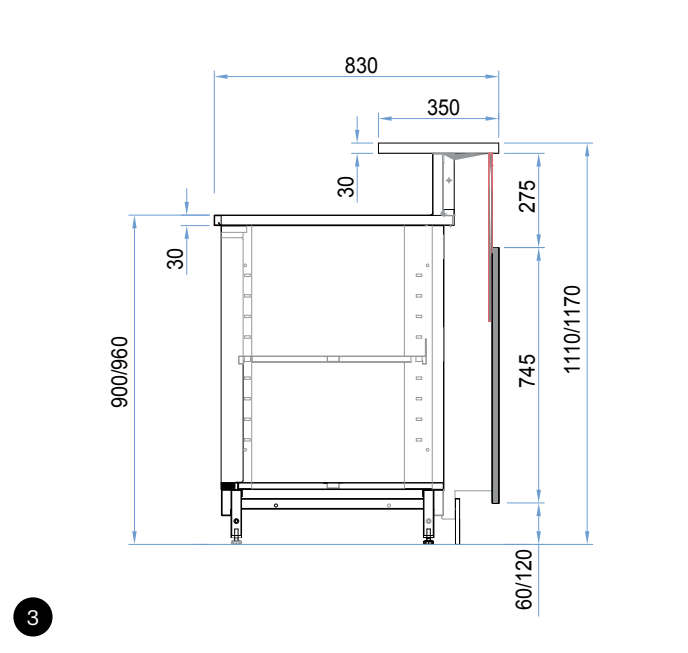
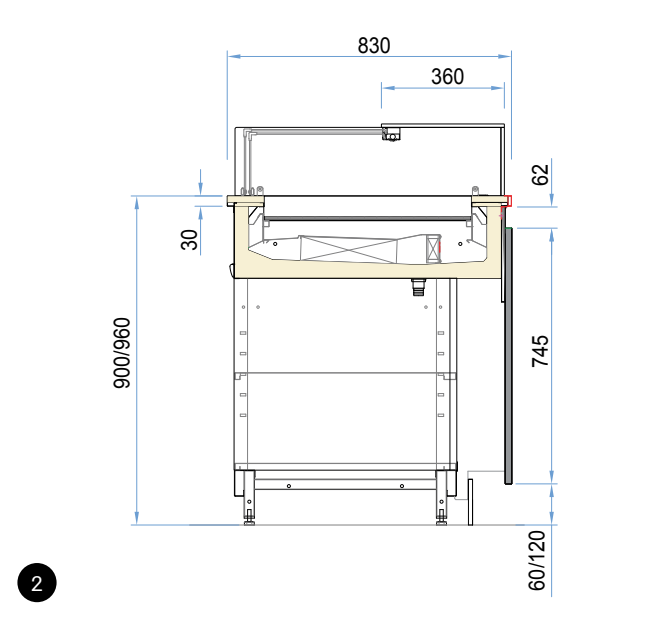
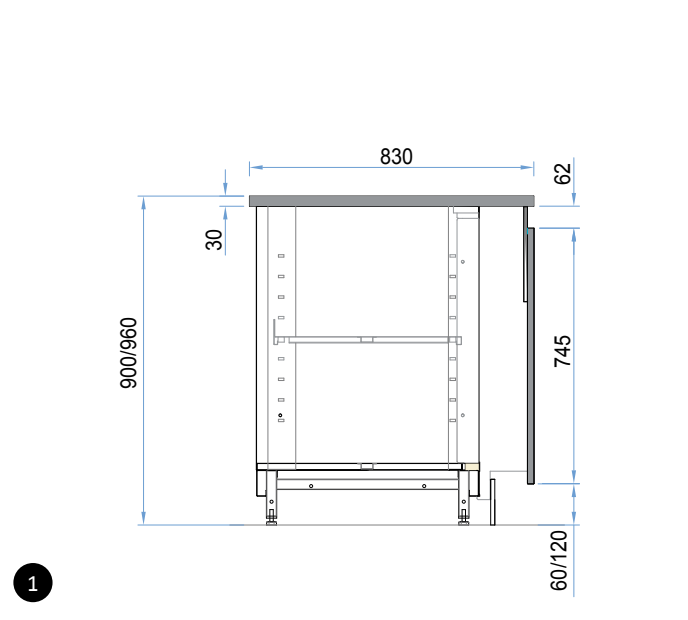

**SEZIONI BEAT / BEAT SECTIONS / SECTIONS BEAT**

Modello / Model / Modèle	Lunghezza modulo / Module length / Longueur module
1 Cassa - servizio	50 / 62.5 / 75 / 100 / 125 / 150 / 175 / 200 / 225 / 250 / 275 / 300 / 325 / 350 / 375 / 400
2 Drop-in	100 / 125 / 150 / 175 / 200 / TDX 150 / TSX 150
3 Banco Bar GH	
4 Banco Bar G2	50 / 62.5 / 75 / 100 / 125 / 150 / 175 / 200 / 225 / 250 / 275 / 300 / 325 / 350 / 375 / 400
5 Banco Bar MO	
6 Vetrina - Esposizione Bassa	100 / 125 / 150 / 175 / 200 / TDX 150 / TSX 150
7 Vetrina - Metro	100 / 130 / 150
8 Vetrina - Combi	100 / 130 / 150
9 Vetrina - Esposizione Alta	100 / 125 / 150 / 175 / 200 / TDX 150 / TSX 150
10 Vetrina - Gelati DLT	125
11 Vetrina - FLAT	100 / 125 / 150 / 175 / 200 / TDX 150 / TSX 150



# Referenze











**ISA S.p.A.**

via Madonna di Campagna 123  
06083 Bastia Umbra (PG) Italy  
T. +39 075 801 71

**isaitaly.com**