



DPN80

DROP-IN

ABACO®



Drop-in Wells

P 80

L 100-125-150-175-200



Display deck can be adjusted in three positions (with 20 mm pitch) and it can accommodate 60x40 cm trays (trays not supplied).

-
- TN RV** - Ventilated refrigeration
 - TN RV CH** - Ventilated chocolate display
 - TC S** - Dry heat
 - TN RV PC** - Ventilated refrigeration and dry heat plate
-

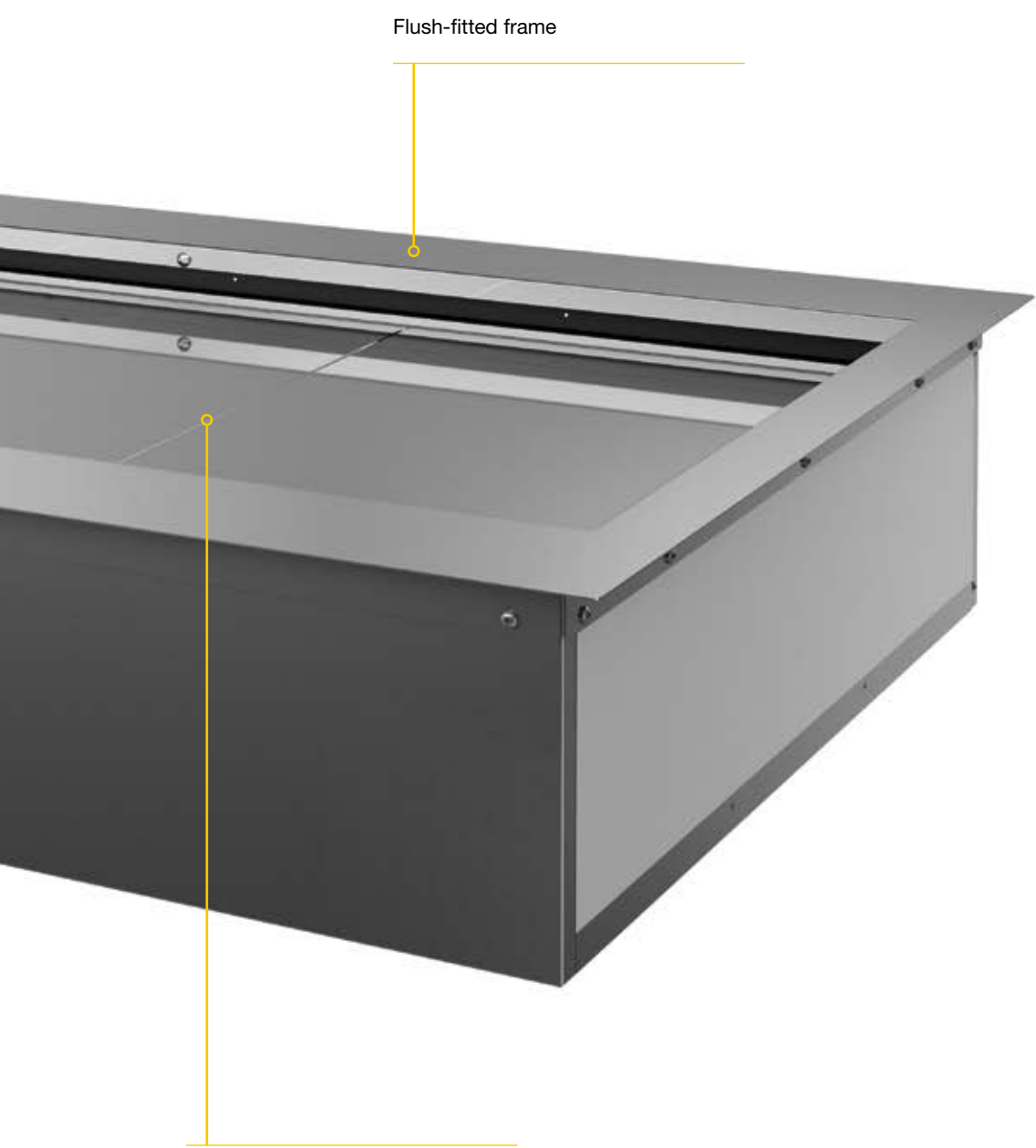

Flush-fitted frame

Accessible for more effective cleaning.

DPN80

DPN80-C

Drop-in Multiplexable display cabinet

H 117-135

P 80

L 100-125-150-175-200

Perfect alignment
with the bar counter
thanks to the total
height from the
ground of 117 cm



TN RV - Ventilated

TN RV - Ventilated with refrigerated storage

TN RV PC - Ventilated chiller & dry heat convertible

TN RV PC - Ventilated chiller & dry heat convertible with storage

TN RV CH - Ventilated chocolate display

TN RV CH - Ventilated chocolate display with storage

TC S - Dry heat



Closing system with slides in transparent methacrylate with easy sliding system.



Tempered glass with extra-clear finish with LED lighting.

Available without countertop, both on operator side and customer side, to allow complete customisation

Multiplexing option between cabinets of the same type

Steel cabinet base with adjustable feet. Wheels optional.

DPN80

Drop-in Multiplexable display cabinet corner unit

H 117-135

P 80

L TDX150-TSX150

Perfect alignment
with the bar counter
thanks to the total
height from the
ground of 117 cm



TN RV - Ventilated

TN RV CH - Ventilated chocolate display

TC S - Dry heat

TN RV PC - Ventilated chiller & dry heat convertible



R290

Closing system with slides
in transparent methacrylate
with easy sliding system.



**Tempered glass
with extra-clear finish**
with LED lighting.

**Available without countertop,
both on operator side and
customer side,** to allow
complete customisation.

Multiplexing option
between cabinets
of the same type.

Steel cabinet base
with adjustable feet.
Wheels optional.

DPN80

Multiplexing

The perfect fit
allows the creation of a single
seamless exhibition surface.

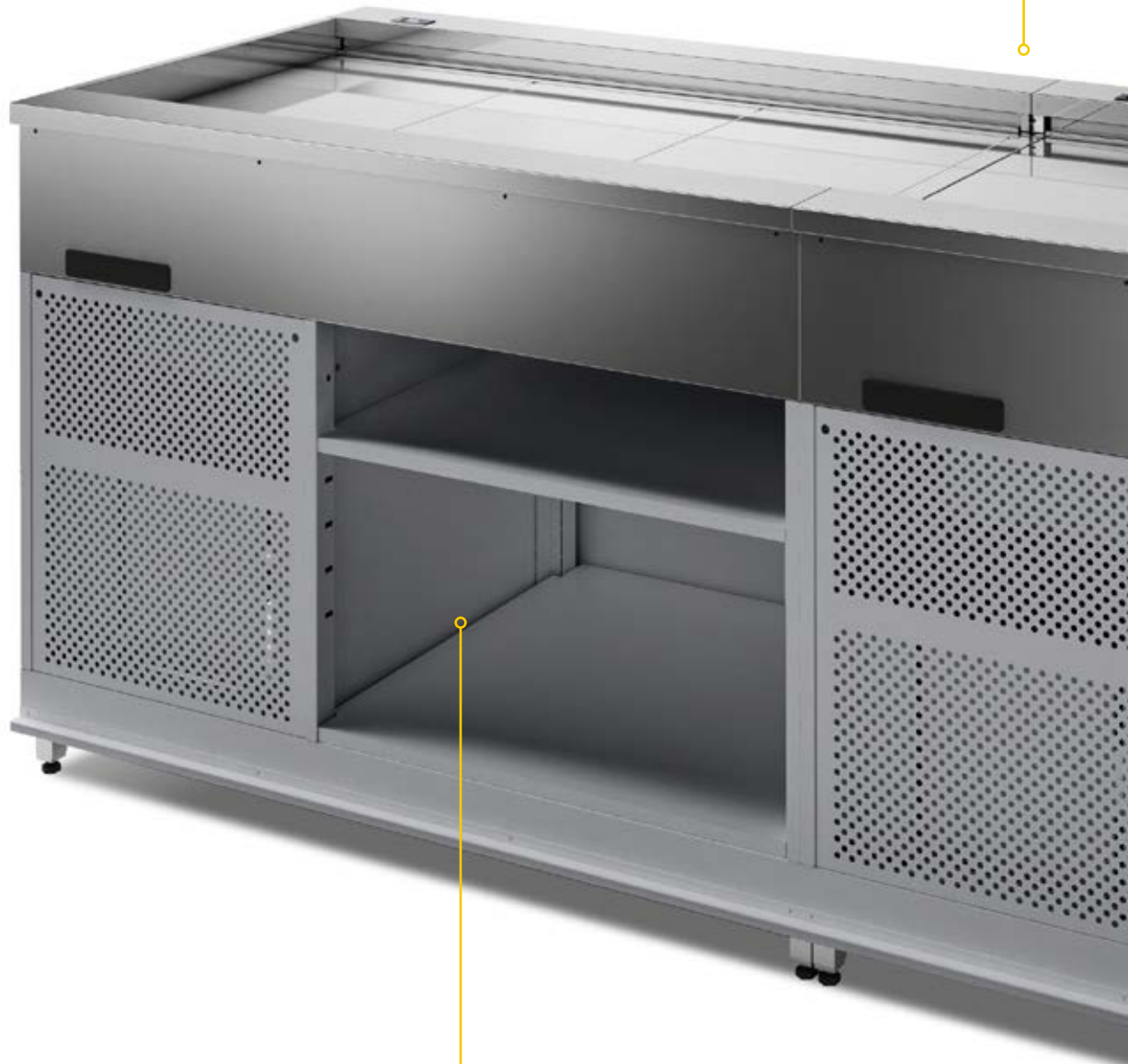

Available with or without
refrigerated storage.



Lower casing profile optimized to provide support to the raised footboard.

DPN80-C

Glued glass case



Glued glass case (only extra EU)

H 117



5.700 K
4.000 K



**Glued glass case
with LED lights
and sliding doors**

H 117



5.700 K
4.000 K

Glass structure with tilt front

Tilt front glass.



**Glass structure
with tilt front,
LED lighting
and sliding doors**

H 117



5.700 K
4.000 K

Tilt front glass

Intermediate shelf
with lighting and heating (option)



**Glass structure
with tilt front,
LED lighting
and sliding doors**

H 135



5.700 K
4.000 K

Operator side

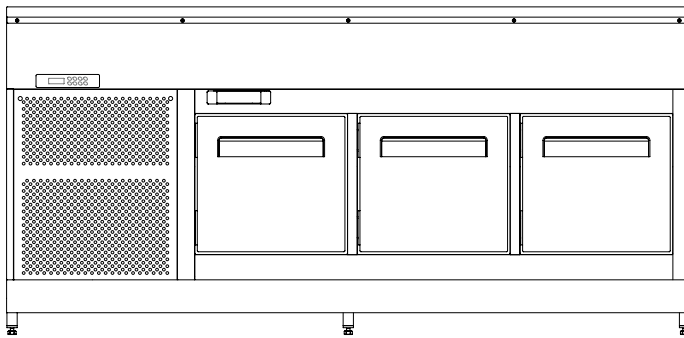

TN refrigerated storage

Module length	UCB (plug-in)	UCR (remote)
100	-	-
125	-	2-door
150	2-door	2-door
175	2-door	3-door
200	2 or 3 door	2 or 3 door
TDX	-	-
TSX	-	-

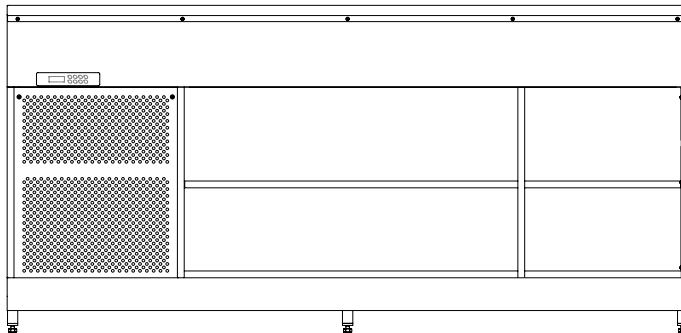

Open storage

Open storage with height adjustable shelves.

Customization



Display deck, front profile and side profiles can be customized.

Black RAL 9004
RAL choice



Hot plate in ceramic material Laminam™

Dark grey finish

Cross sections

TN RV

TN RV PC

TN RV CH

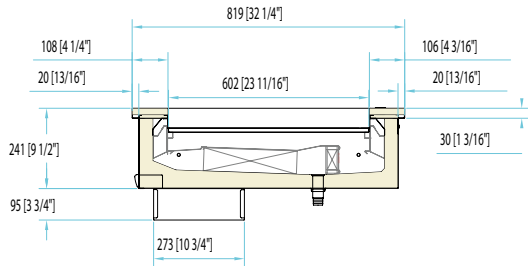

Well

H 117-135

P 80

L 100-125-150-175-200

TDX150-TSX150

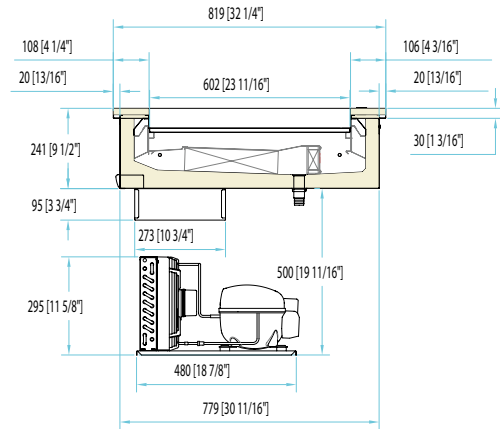

Well with factory-connected condensing unit

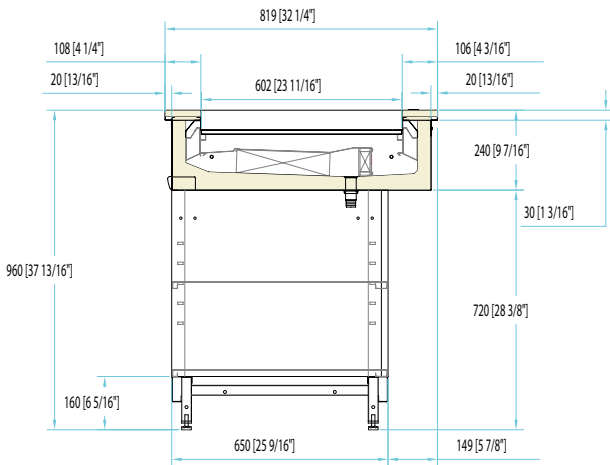

Well on neutral counter

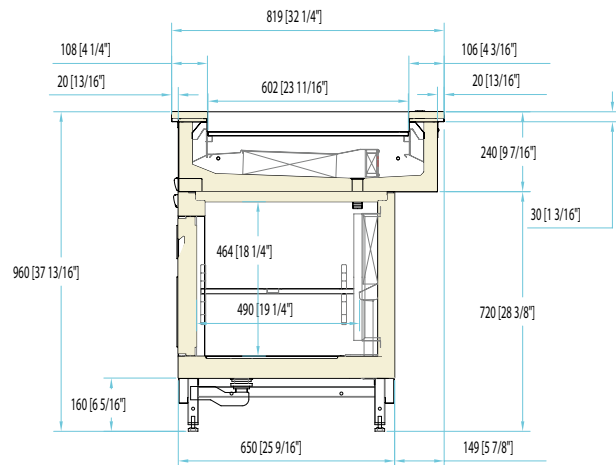

Well on refrigerated storage counter base

TN RV - Ventilated
TN RV - Ventilated with refrigerated storage
TN RV PC - Ventilated chiller and hot plate convertible
TN RV PC - Ventilated chiller and hot plate convertible with refrigerated storage

TN RV CH - Ventilata chocolate display
TN RV CH - Ventilata chocolate display with display storage
TC S - Dry heat

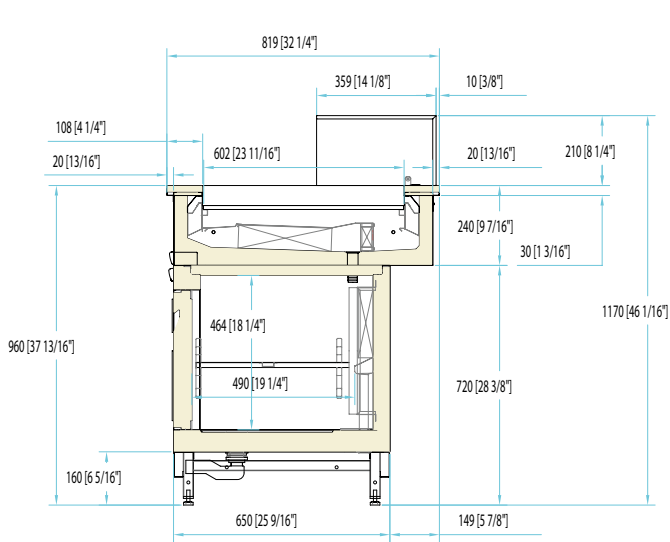

H117 Display cabinet with glued glass open case and refrigerated storage (only extra EU)

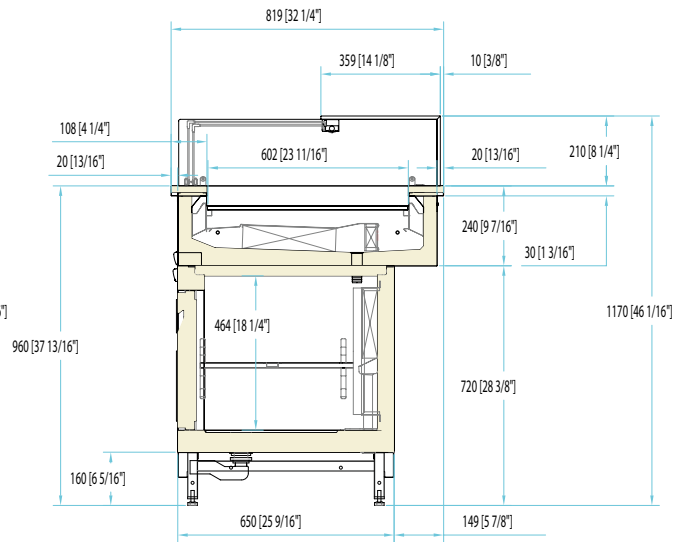

H117 Display cabinet with glued glass lighted case and refrigerated storage

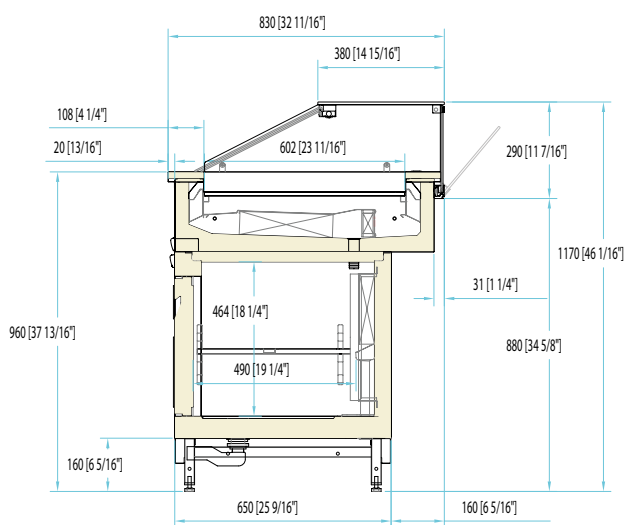

H117 Display cabinet with lighted tilt glass structure and refrigerated storage

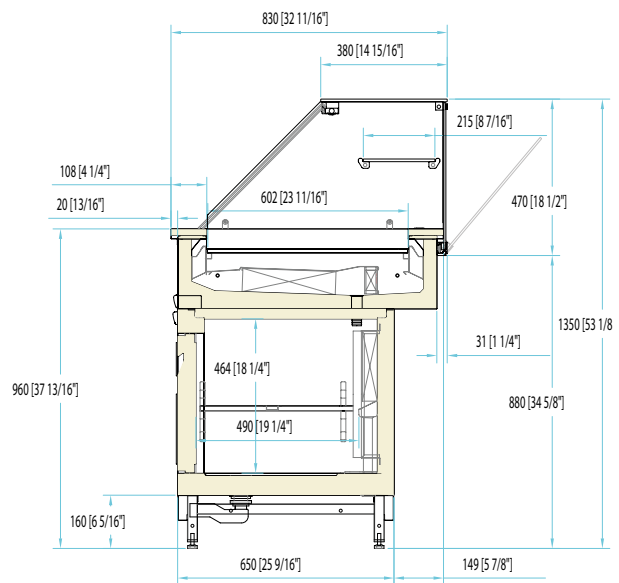

H135 Display cabinet with lighted tilt glass structure and refrigerated storage

Cross sections TC S

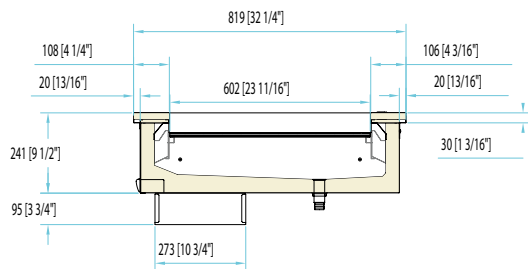

Well

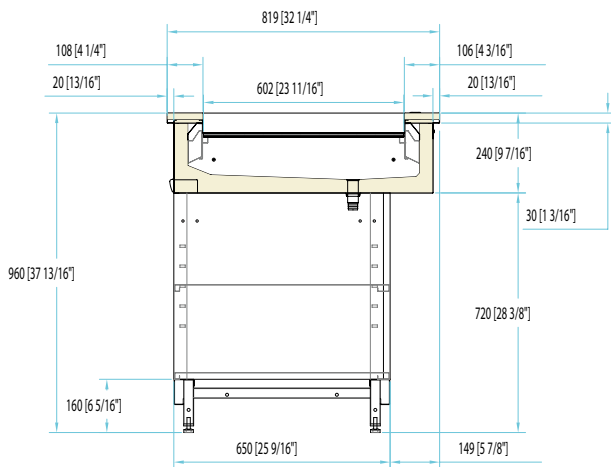

Well on neutral counter base

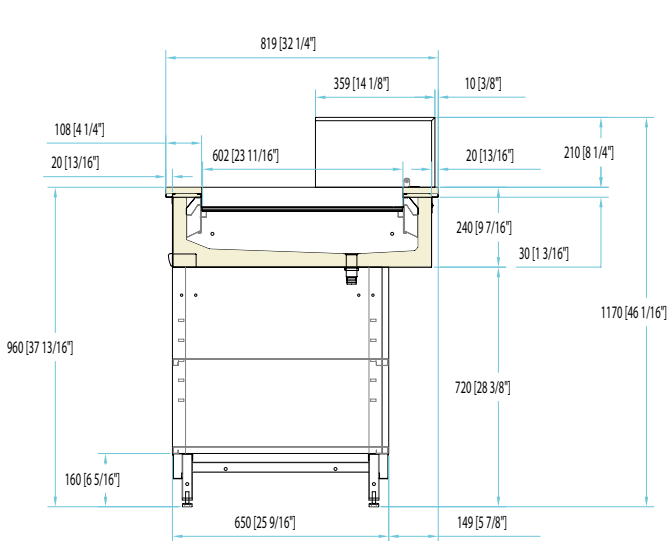

H117 Display cabinet with glued glass open case on neutral counter base

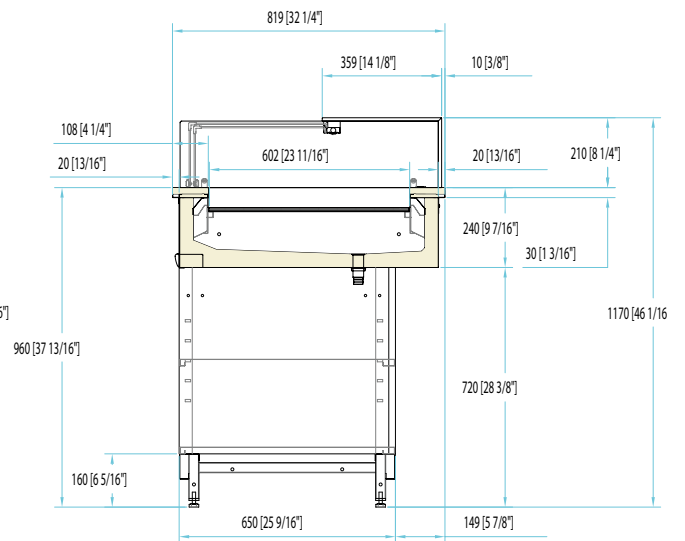

H117 Display cabinet with glued glass lighted case on neutral counter base

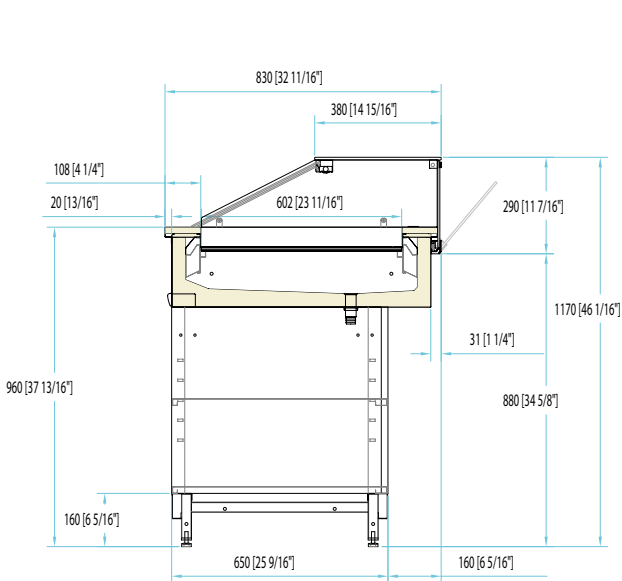

H117 Display cabinet with lighted tilt glass structure on neutral counter base

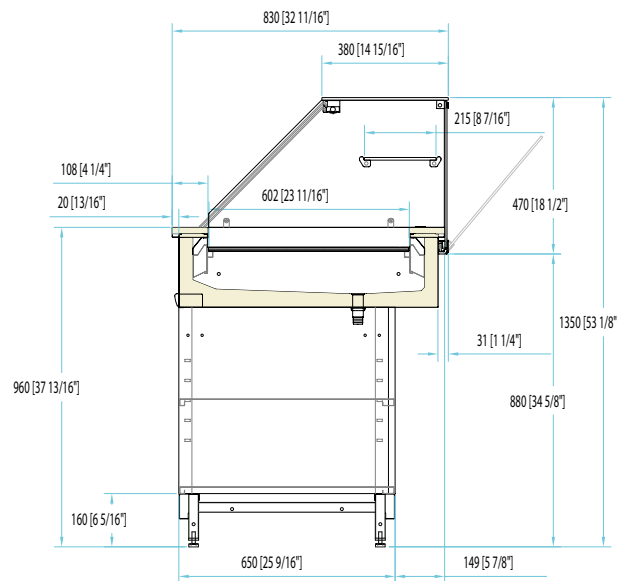





H135 Display cabinet with lighted tilt glass structure on neutral counter base

Technical data

UCB plug-in condensing unit

MODULE LENGTH	100	125	150	175	200
Climate class	3				
Climate conditions	25°C/60% UR				
Ventilated refrigeration operating temperature	-1/+7 °C				
Chocolate display operating temperature	+14/+16 °C				
Hot plate operating temperature	65 °C				
Compressors [q.ty/ type]	1/ hermetic				
Defrost	compressor off-cycle				
Power Supply [V/hz]	230/50				
Refrigerant	R290				

VENTILATED

Heat extraction rate (Ørun) [W@-10]	721	721	934	934	1099
Rated absorbed power [W/A]	411/2,9	418/3	498/3,6	504/3,65	567/4,1
Absorbed power during defrost [W/A]	56/0,4	63/0,45	78/0,56	84/0,61	97/0,7
Energy class					

CHOCOLATED DISPLAY

Heat extraction rate (Ørun) [W@-10]	721	721	721	934	1099
Rated absorbed power [W/A]	595/2,69	502/2,72	597/3,2	603/3,3	788/4,3
Absorbed power during defrost [W/A]	242/1,32	249/1,35	307/1,66	313/1,7	450/2,44

DRY HEAT

Rated absorbed power [W/A]	740/3,6	930/4,5	1120/5,4	1320/6,4	1500/7,2
----------------------------	---------	---------	----------	----------	----------

VENTILATED REFRIGERATION - UCR remote condensing unit

MODULE LENGTH	100	125	150	175	200
Refrigerants	R404A/ R452A				
Climate class	4				
Climate conditions	30°C/55% UR				
Defrost	compressor off-cycle				
Power Supply [V/hz]	230/50				
Absorbed power [W/A]	56	63	78	84	97
Absorbed power of remote condensing unit [W]	486	486	760	760	660
Condensing unit weight [kg]	14,8	14,8	20	20	25,5
Condensing unit dimensions LxDxH[mm]	480x330x295	480x330x295	500x330x297	500x330x297	490x385x295
Refrigerant piping diameter: Liquid/Suction 0-15mt	12/8	12/8	12/8	12/8	12/8
Refrigerant piping diameter : Liquid/Suction 16-30mt	14/8	14/8	14/8	14/8	14/8

CHOCOLATE DISPLAY - UCR remote condensing unit

MODULE LENGTH	100	125	150	175	200
Refrigerants	R404A/ R452A				
Climate class	4				
Climate conditions	30°C/55% UR				
Defrost	compressor off-cycle				
Power Supply [V/hz]	230/50				
Absorbed power [W/A]	243	249	307	313	450
Absorbed power of remote condensing unit [W]	486	486	486	760	760
Condensing unit weight [kg]	14,8	14,8	14,8	20	25,5
Condensing unit dimensions LxDxH[mm]	480x330x295	480x330x295	480x330x295	500x330x297	500x330x297
Refrigerant piping diameter: Liquid/Suction 0-15mt	12/8	12/8	12/8	12/8	12/8
Refrigerant piping diameter: Liquid/Suction 16-30mt	14/8	14/8	14/8	14/8	14/8