

Metro ST

METRO

H 117 • 135

P 80

L 100 • 130

Pastry • Bakery • Chocolate • Hot snack • Food & Beverage

Installation

- Plug-in (multiplexable)
- Remote (multiplexable)

Configuration

- Glass shelves 2 (H117)
- Glass shelves 3 (H135)

Temperature

- -1/+5 °C (TN)
- +14/+16 °C (CH)
- +65 °C (TCS)

Refrigerant

- R290 (Plug-in)
- R452A (Remote)

Refrigeration

Ventilated (TN-CH)

Compressor

Hermetic

Defrost

Off cycle (TN-CH)

Climate class

3

Front glass

Double

Side glasses

Double

Rear closing system

Glass sliding doors

Opening system

Openable glass structure
towards the bottom

Lighting

- 3000 K
- 4000 K (Optional)
- 5700 K (Optional)

Base

- Height adjustable feet
- Swivel casters with brake
(Optional)

Color

White RAL 9003

Installazione

- Plug-in (canalizzabile)
- Remoto (canalizzabile)

Configurazione

- Ripiani in vetro 2 (H117)
- Ripiani in vetro 3 (H135)

Temperatura

- -1/+5 °C (TN)
- +14/+16 °C (CH)
- +65 °C (TCS)

Refrigerante

- R290 (Plug-in)
- R452A (Remoto)

Refrigerazione

Ventilata (TN-CH)

Compressore

Ermetico

Sbrinamento

Fermata compressore (TN-CH)

Classe Climatica

3

Vetro frontale

Doppio (Camera)

Vetri laterali

Doppio (Camera)

Chiusura posteriore

Scorrevoli in vetro

Apertura anteriore

Apertura ribaltabile
verso il basso

Illuminazione

- 3000 K
- 4000 K (Optional)
- 5700 K (Optional)

Basamento

- Piedini regolabili in altezza
- Ruote pivotanti con freno
(Optional)

Colore

Bianco RAL 9003



R290

	TN	TB	TB/TN	TC	TC/TN	N
	Chiller	Freezer	Dual Temp	Heated	Hot&Cold	Non-refrigerated

RS - Static						
RV - Ventilated		•				
RS/TC S - Static and Dry Heat convertible						
RV/TC S - Ventilated / Dry Heat convertible						
HUR - Meat						
CH - Chocolate		•				
TC S - Dry Heat				•		
TC BM - Bainmarie						
N - Non-refrigerated						•



H 135

Metro ST

		100		130	
		RV TN	RV CH	RV TN	RV CH
External dimensions (LxDxH) Dimensioni esterne (LxPxH)	H117 H135	1000 x 833 x 1170 / 1216 mm 1000 x 833 x 1350 / 1397 mm		1300 x 833 x 1170 / 1216 mm 1300 x 833 x 1350 / 1397 mm	
Capacity (gross / net) Capacità (lorda / netta)	H117 H135	523,5 / 237,8 lt 652 / 305,6 lt		687 / 312,1 lt 855,5 / 401,2 lt	
Weight (net) Peso (netto)	H117 H135	200 kg 210 kg		205 kg 215 kg	
Refrigeration Refrigerazione		Ventilated Ventilata			
Refrigerant Refrigerante		R290			
Climate class Classe climatica		3			
Operating conditions Condizioni ambientali		25 °C / 60 %RH			
Product temperature Temperatura prodotto		-1/+5 °C	+14/+16 °C	-1/+5 °C	+14/+16 °C
Compressor (q.ty - type) Compressore (q.tà - tipologia)		1 - Hermetic 1 - Ermetico			
Defrost Sbrinamento		Off Cycle Fermata compressore			
Power supply Alimentazione		230 V / 1 Ph / 50 Hz			
Electrical input (nominal) Assorbimento elettrico (regime)		530 W / 3,1 A	750 W / 4,2 A	550 W / 3,1 A	770 W / 4,3 A
Electrical input (defrost) Assorbimento elettrico (sbrinamento)		35 W / 0,2 A			

Technical sheet about models whit condensing unit included with air cooled
Dati tecnici riferiti a modelli con unità a bordo con condensazione ad aria

Setup

Allestimento

Shelf (LxD) Ripiano (LxP)	907 x 400 mm	1207 x 400 mm
Bottom shelf (LxD) Ripiano di fondo (LxP)	910 x 602 mm	1210 x 602 mm

H117
RV TN - RV CH

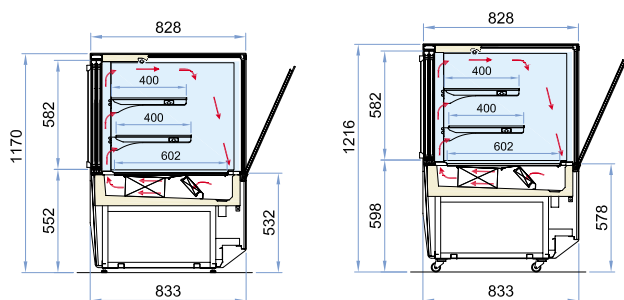

H135
RV TN - RV CH

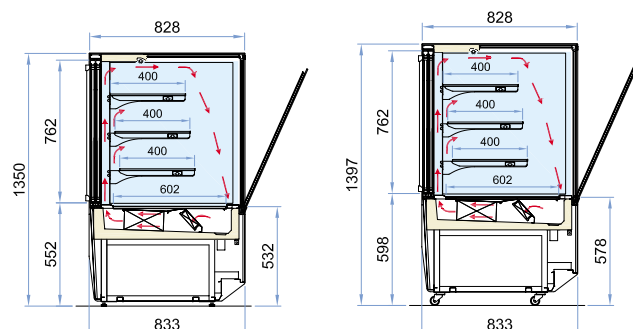

Metro ST

		100		130	
		TC S	N	TC S	N

External dimensions (LxDxH) Dimensioni esterne (LxPxH)	H117 H135	1000 x 833 x 1170 / 1216 mm 1000 x 833 x 1350 / 1397 mm		1300 x 833 x 1170 / 1216 mm 1300 x 833 x 1350 / 1397 mm	
Capacity (gross / net) Capacità (lorda / netta)	H117 H135	-		-	
Weight (net) Peso (netto)	H117 H135	175 kg 185 kg		180 kg 190 kg	
Refrigeration Refrigerazione		-			
Refrigerant Refrigerante		-			
Climate class Classe climatica		3			
Operating conditions Condizioni ambientali		25 °C / 60 %RH			
Product temperature Temperatura prodotto		+65 °C	-	+65 °C	-
Compressor (q.ty - type) Compressore (q.tà - tipologia)		-			
Defrost Sbrinamento		-			
Power supply Alimentazione		230 V / 1 Ph / 50 Hz			
Electrical input (nominal) Assorbimento elettrico (regime)		800 W / 3,5 A	24 W / 0,2 A	930 W / 4,2 A	33 W / 0,3 A
Electrical input (defrost) Assorbimento elettrico (sbrinamento)		-			

Setup

Allestimento

Shelf (LxD) Ripiano (LxP)		907 x 400 mm		1207 x 400 mm	
Bottom shelf (LxD) Ripiano di fondo (LxP)		910 x 602 mm		1210 x 602 mm	

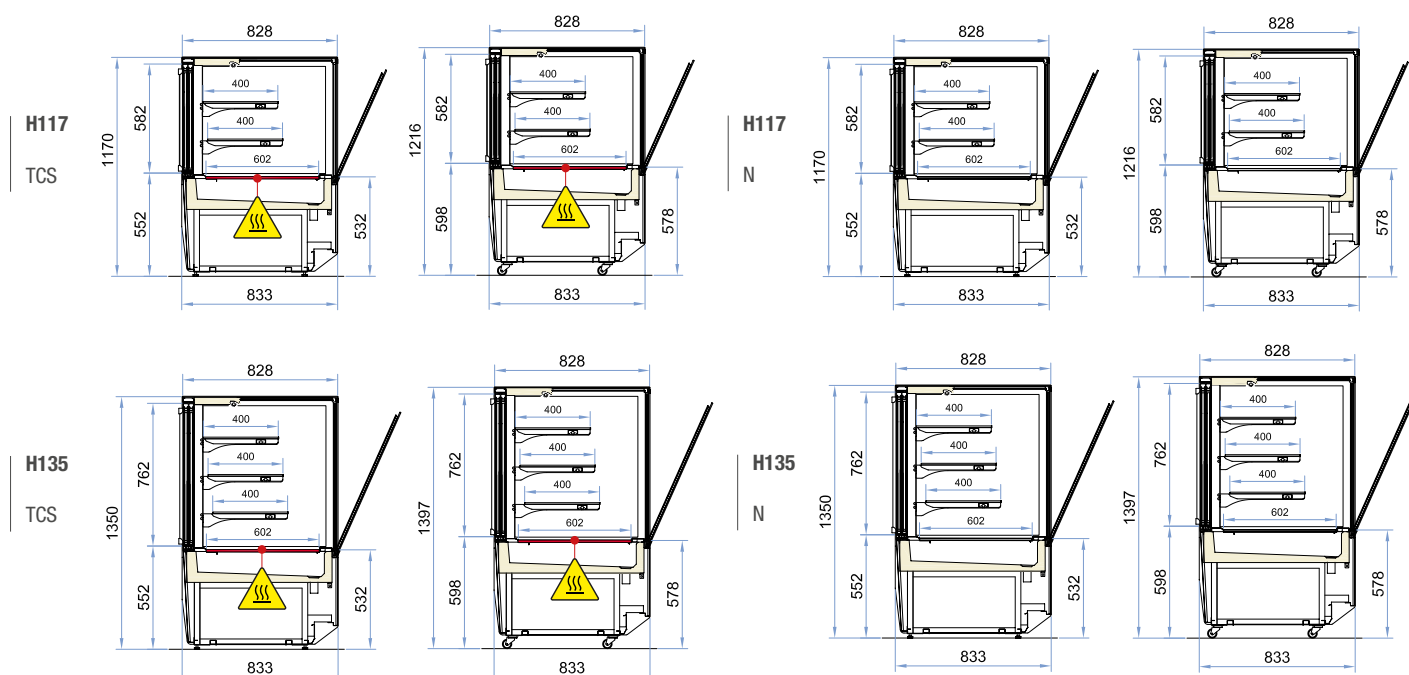

Metro ST Self

METRO

H 117 • 135

P 80

L 100 • 130

Food & Beverage

TN TB TB/TN TC TC/TN N
Chiller Freezer Dual Temp Heated Hot&Cold Non-refrigerated

RS - Static	
RV - Ventilated	•
RS/TC S - Static and Dry Heat convertible	
RV/TC S - Ventilated / Dry Heat convertible	
HUR - Meat	
CH - Chocolate	
TC S - Dry Heat	
TC BM - Bainmarie	
N - Non-refrigerated	

Installation

- Plug-in (multiplexable)
- Remote (multiplexable)

Configuration

- Glass shelves 2 (H117)
- Glass shelves 3 (H135)

Temperature

-1/+7 °C

Refrigerant

- R290 (Plug-in)
- R452A (Remote)

Refrigeration

Ventilated

Compressor

Hermetic

Defrost

Off cycle

Climate class

3

Side glasses

Double

Rear closing system

Glass sliding doors

Front closing system

Self rolling curtain

Lightning

- 3000 K
- 4000 K (Optional)
- 5700 K (Optional)

Base

- Height adjustable feet
- Swivel casters with brake (Optional)

Color

White RAL 9003

Installazione

- Plug-in (canalizzabile)
- Remoto (canalizzabile)

Configurazione

- Ripiani in vetro 2 (H117)
- Ripiani in vetro 3 (H135)

Temperatura

-1/+7 °C

Refrigerante

- R290 (Plug-in)
- R452A (Remoto)

Refrigerazione

Ventilata

Compressore

Ermetico

Sbrinamento

Fermata compressore

Classe Climatica

3

Vetri laterali

Doppio (Camera)

Chiusura posteriore

Scorrevoli in vetro

Chiusura anteriore

Tendina manuale autoavvolgente

Illuminazione

- 3000 K
- 4000 K (Optional)
- 5700 K (Optional)

Basamento

- Piedini regolabili in altezza
- Ruote pivotanti con freno (Optional)

Colore

Bianco RAL 9003



R290



H 135

Metro ST Self

	100	130
	RV TN	RV TN

External dimensions (LxDxH) Dimensioni esterne (LxPxH)	H117 H135	1000x833x1170/1216 mm 1000x833x1350/1397 mm	1300x833x1170/1216 mm 1300x833x1350/1397 mm
Capacity (gross / net) Capacità (lorda / netta)	H117 H135	105,8 / 410 lt 264,6 / 501,1 lt	258,1 / 538 lt 347,2 / 658 lt
Weight (net) Peso (netto)	H117 H135	200 kg 210 kg	205 kg 215 kg
Refrigeration Refrigerazione		Ventilated Ventilata	
Refrigerant Refrigerante		R290	
Climate class Classe climatica		3	
Operating conditions Condizioni ambientali		25 °C / 60 %RH	
Product temperature Temperatura prodotto		-1/+7 °C	
Compressor (q.ty - type) Compressore (q.tà - tipologia)		1 - Hermetic 1 - Ermetico	
Defrost Sbrinamento		Off Cycle Fermata compressore	
Power supply Alimentazione		230 V / 1 Ph / 50 Hz	
Electrical input (nominal) Assorbimento elettrico (regime)		850 W / 3,9 A	910 W / 4,1 A
Electrical input (defrost) Assorbimento elettrico (sbrinamento)		60 W / 0,3 A	

Technical sheet about models whit condensing unit included with air cooled
Dati tecnici riferiti a modelli con unità a bordo con condensazione ad aria

Setup

Allestimento

Shelf (LxD) Ripiano (LxP)	907 x 260 mm	1207 x 260 mm
	907 x 350 mm	1207 x 350 mm
	907 x 400 mm	1207 x 400 mm
Bottom shelf (LxD) Ripiano di fondo (LxP)	910 x 602 mm	1210 x 602 mm

