

LABOR



ISA S.p.A.

Via Madonna di Campagna 123 - 06083 Bastia Umbra PG - Italy















T. +39 075 801 71 • F. +39 075 800 09 00 • E. customerservice@isaitaly.com

www.isaitaly.com



1.	NOTES / WARNINGS	4
2.	MANUFACTURER	10
3.	WARRANTY TERMS AND CONDITIONS	10
4.	EQUIPMENT IDENTIFICATION	11
5.	COMPOSITION	12
6.	USE	12
7.	LOAD LIMITS	12
8.	SAFETY	13
8.1	SAFETY DEVICES INSTALLED	13
8.2	FIXED GUARDS	13
8.3	ISOLATING THE ELECTRIC POWER SUPPLY	13
8.4	CIRCUIT FAULTS	13
8.5	WARNING PLATES	13
8.6	FALLING OBJECTS	13
8.7	COOLING	13
8.8	FOOD SAFETY (PACKAGED PRODUCTS)	13
9.	RESIDUAL RISKS	14
9.1	RISK OF CONTACT WITH LIVE PARTS	14
9.2	FIRE	14
9.3	EXPLOSIVE ATMOSPHERE	14
9.4	SLIPPING	14
9.5	TRIPPING	14
10.	DISPOSAL OF WASTE MATERIAL	15
11.	INSTALLATION	16
11.1	UNPACKING	16
11.2	HANDLING	18
11.3	STORAGE	18
11.4	ENVIRONMENTAL CONDITIONS	18
11.5	ELECTRICAL CONNECTION	18
11.6	WALL MOUNTING	19
11.7	LEVELLING	19
12.	MAINTENANCE	20
13.	FAULTS - TECHNICAL AFTER-SALES ASSISTANCE	21
14.	TECHNICAL SPECIFICATIONS	22
14.1	SHELF LOADS	23
14.2	CLOSURE WITH KEY	23
15.	CONTROL PANEL	24
15.1	USER INTERFACE	25
16.	CLEANING	27
16.1	INTERNAL	27
16.2	CONDENSING UNIT	28
16.3	DEFROST WATER COLLECTION TRAY (IF PRESENT)	29
17.	PROLONGED APPLIANCE SWITCH-OFF	29

The manual contains symbols to attract the reader's attention and highlight particularly important aspects. The table below illustrates the meaning of the various symbols used.

	READ THE MANUAL
	DANGER: ENERGISED ELECTRICAL PARTS
	ATTENTION / DANGER
	INFORMATION
	VISUAL OBSERVATION
	DANGER: SLIPPING
	DANGER: TRIPPING
	EARTHING
	USE OF PROTECTIVE CLOTHING
	REQUEST FOR MAINTENANCE OR OPERATIONS THAT MUST BE PERFORMED BY QUALIFIED PERSONNEL OR BY A TECHNICAL ASSISTANCE CENTRE
	IMPORTANT INFORMATION
	OPERATIONS THAT MUST BE PERFORMED BY TWO PERSONS
	NOTES / WARNINGS
	WASTE DISPOSAL
	RECYCLABLE MATERIALS

1. NOTES / WARNINGS



NOTE

The contents of this manual are of a technical nature and are owned by **ISA**. It is forbidden to reproduce, circulate or modify all or part of its content without written consent. Any infringement will be legally pursued.

The manual and the conformity certificate are an integral part of the equipment and should always accompany the product in the event of a transfer to a new location or to a new owner. The user is responsible for the integrity of these documents, for their consultation and during the whole life cycle of the equipment itself. Keep this manual in a safe place. It should be available for consultation near the equipment at all times. If lost or destroyed, you can request a copy of the manual from **ISA** by specifying the exact model, serial number and year of manufacture. The manual reflects the manufacturing technology at the time of supply. The manufacturer reserves the right to modify its products in any way it deems necessary, with no obligation to update manuals and machines relating to previous manufacturing batches.

The equipment can be used by children no younger than 8 and by persons with reduced physical, sensory or mental capabilities, or lacking experience or necessary knowledge, as long as supervised or after having received training regarding safe use of the equipment and have an understanding of the inherent risks involved. Do not allow children to play with the device. The cleaning and maintenance that the user will carry out must not be undertaken by children without supervision.

Always refer to this manual before going ahead with any operation. Before doing any type of work, disconnect the equipment from the power supply. Any work on electric and electronic parts or cooling system components should only be carried out by trained personnel in compliance with current laws.

The Manufacturer cannot be held liable for any damage to persons, animals or to the product in the following cases:

- improper use of the equipment or use of the appliance by unqualified or unauthorised personnel.
- Failure to comply with current legislation.
- Incorrect installation and/or power supply faults.
- Failure to observe the instructions contained in this Manual.
- Failure to follow the maintenance schedule.
- Unauthorised modifications.
- installation of non-original spare parts in the equipment.
- installation and use of the equipment for purposes other than those for which it was designed and sold.
- Tampering with or damage to the power supply cable.

1. NOTES / WARNINGS

Liability for applying the safety instructions contained in this manual is held by the technical personnel responsible for the intended use of the equipment, who should ensure that authorised personnel:

- Are qualified to carry out the requested activity.
- Are aware of and carefully comply with the instructions contained in this document.
- Are aware of, and apply, the general safety standards applicable to the equipment.

The buyer is responsible for training personnel using the appliance on the risks, safety devices and general health and safety rules required by the laws of the country where the appliance is installed. Users/operators should be aware of the position of all the controls and how they work, as well as of the features of the appliance. They should also read this manual in its entirety. Maintenance work should be conducted by qualified personnel after the appliance has been prepared adequately.

DANGER



Unauthorised tampering or replacement of one or more parts of the appliance, use of accessories that modify the use of the same and use of spare parts different to those recommended, can become the cause of injury.

DANGER



Any work conducted on the appliance must involve disconnection from the power socket and in any case, none of the protective elements (grid, casing) should be removed by non-qualified staff. The appliance should not be operated when these protective elements have been removed. Before carrying out any cleaning, maintenance or replacement operation, disconnect the equipment from the mains by unplugging it from the electrical socket. During these operations the operator must be able to ensure that the plug remains disconnected.

NOTE



In order to avoid compromising the functionality and safety of the appliance, the particularly complex installation and maintenance activities are not documented in this manual and are performed by the undersigned company.

Never use electric devices inside this appliance. Do not use mechanical devices or other means to accelerate the defrosting process, other than those recommended by the manufacturer. Keep the air vents in the casing of the appliance or in the structure built into the wall free of obstructions. Do not damage the refrigeration circuit.

The A-weighted emission sound pressure level is lower than 70 dB (A).

1. NOTES / WARNINGS

RISK OF EXPLOSION

Do not store products containing flammable propellants or explosives.

ISA uses materials of the best quality and as they enter the company, we constantly monitor their storage the use as part of the manufacturing process to prevent damage, deterioration and failure. All manufacturing elements have been designed and manufactured in order to guarantee high safety and reliability standards. All appliances are subjected to a strict testing procedure before delivery. However, please bear in mind that product performance over time depends on correct use and adequate maintenance. This manual contains the necessary instructions to maintain the appliance's initial appearance and functions over time.

The use and maintenance manual contains the information required to understand the operating modes of the appliance and for its correct use, in particular: the technical description of the various functional units, accessories and safety systems, operation, use of instrumentation and interpretation of any diagnostic warnings, main procedures and information relating to the ordinary maintenance operations. For correct use of the appliance, the working environment should comply with current health and safety standards.

The safety requirements, indications, standards and notes illustrated in the various chapters of the manual are aimed at establishing a code of conduct and a series of obligations to be observed when performing the various activities, in order to create safe conditions for personnel, the equipment and the surrounding environment.

The safety standards reported in this document are intended for trained, authorised personnel responsible for:

- Transport
- Installation
- Operation
- Management
- Maintenance
- Cleaning
- Decommissioning
- Disposal



ATTENTION

Reading of this manual, albeit in full, is no substitute for adequate user experience. Therefore it should only be considered a useful reminder of the technical features and the main operations to be performed.

1. NOTES / WARNINGS



WARNING

The installers and users **MUST** read and understand the instructions contained herein before any operation on the appliance.

STAFF TRAINING

The buyer is responsible for ensuring personnel who will use the appliance and maintenance technical staff are instructed and trained adequately. The manufacturer is available for advice, clarifications, etc. so that the operator and technical staff can use the appliance correctly. To ensure operator safety, appliance devices should be kept in constant working order. This manual is intended to illustrate the use and maintenance of the appliance. The operator has a responsibility and duty to carefully observe the instructions contained within it.

Failure to comply with safety standards may result in injury to personnel and damage to the equipment components and control unit. The user can contact the dealer to request additional information not contained in this document, or suggest improvements, at any time.



Before the product is delivered to the customer, a trained technical member of staff must check that the appliance is operating correctly in order to achieve maximum performance.

1. NOTES / WARNINGS

COOLANTS

R744

The refrigerant **R744** is a gas that is compatible with the environment. Be very careful when transporting and installing the appliance and during scrapping to avoid damaging the refrigerant circuit pipes.

IN THE EVENT OF DAMAGE:

Keep flames or sources of ignition away from the appliance. Properly ventilate the premises for a few minutes. Turn the unit off, pull out the plug. **Notify the customer service department.**



ATTENTION

The refrigerant system works at High Pressure. Do not tamper with the system, but call a specialised and qualified technician before disassembly.



ATTENTION

Maintenance must be performed by qualified personnel that has been to work with flammable refrigerants.

R290

The refrigerant **R290** is a gas that is compatible with the environment but **is extremely flammable**. Be very careful when transporting and installing the appliance and during scrapping to avoid damaging the refrigerant circuit pipes.

IN THE EVENT OF DAMAGE:

Keep flames or sources of ignition away from the appliance. Properly ventilate the premises for a few minutes. Turn the unit off, pull the plug. Notify the customer service department. The more refrigerant containing an appliance, the greater must be the environment in which there is the unit. In areas too small, in the event of leakage can form a flammable mixture of air and gas. **The volume of the room where the appliance is installed must be at least 19 m³ for each cooling system present in the room.**



ATTENTION

Maintenance must be carried out by trained technical personnel authorised to work on flammable refrigerants.

1. NOTES / WARNINGS

COOLANTS

R600a

The refrigerant **R600a** is a gas that is compatible with the environment, but is **highly flammable**. Be very careful when transporting and installing the appliance and during scrapping to avoid damaging the refrigerant circuit pipes.

IN THE EVENT OF DAMAGE:

Keep flames or sources of ignition away from the appliance. Properly ventilate the premises for a few minutes. Turn the unit off, pull the plug. Notify the customer service department. The more refrigerant containing an appliance, the greater must be the environment in which there is the unit. In areas too small, in the event of leakage can form a flammable mixture of air and gas. **The volume of the room where the appliance is installed must be at least 17 m³ for each cooling system present in the room.**



ATTENTION

Maintenance must be carried out by trained technical personnel authorised to work on flammable refrigerants.

2. MANUFACTURER

ISA S.p.A.

Via Madonna di Campagna 123

06083 Bastia Umbra PG - Italy

T. +39 075 801 71

F. +39 075 800 09 00

E. customerservice@isaitaly.com

www.isaitaly.com

3. WARRANTY TERMS AND CONDITIONS

The seller guarantees their equipment for a period of 12 (twelve) months from delivery.

The warranty includes repairs or replacements of any faulty parts due to manufacturing processes or installation after written communication has been received, stating the appliance serial number and date of installation.

Not included in the warranty:

- Incorrect use of the appliance.
- Incorrect connection to the power grid.
- Normal wear of the components (such as breakage of the compressors, of the neon/LED lights, etc.) if not due to manufacturing defects.
- Calls for installation, technical instructions, adjustments, condenser cleaning.

If the seller's technical staff detect any tampering, unauthorised repairs or inappropriate use of appliance the warranty will be invalidated.

Shipment of components covered by the warranty is freight collect only.

Any damage to the appliance detected at the time of delivery due to transport must be reported on the same shipping note to claim compensation from the carrier.





The seller cannot be held liable in the event of damage to accepted products due to appliance faults.

4. IDENTIFYING THE EQUIPMENT

Find the label affixed on the machine to read the technical data.

Check the machine model and the power supply voltage before you perform any operation.

If discrepancies are found, contact the manufacturer or the company that offer the supply immediately.

1		2			
Tip. 3		Mod. 4			
Art. 5					
Data prod. - Prod. Date 6	Ordine prod. - Prod. Order 7	Ord. cliente - Cust. Order 8	Classe Prodotto - Product Class (En23953) 9		
Matricola - Serial Number 10				Matr. di Proprietà - Property Number 11	
12 V~	13 Hz		14 A		15 W
			16 W		
Potenza nominale - Rated Power ❄️ 17 W	Potenza in Sbrinam. - Defrosting Power ❄️ 18 W	Psig min 19	Psig max 20	Classe Sicur. - Safety Class (EN 60335-2-89) 21	
Corrente nominale - Rated Current ❄️ 22 A	Corrente in Sbrinam. - Defrosting Current ❄️ 23 A	Carico rip. - Shelf load 24 Kg/m2	Carico vasca - Tank load 25 Kg/m2		
Tipo Refrigerante Refrigerant Type 1 . 2 . 26 3 .		Peso Refrigerante Refrigerant Weight Kg 27 Kg Kg		Volume Lordo - Gross Volume 28 L Espandente - Foaming Agent 29	
 30					
<small>CONTIENE GAS FLUORURATI AD EFFETTO SERRA DISCIPLINATI DAL PROTOCOLLO DI KYOTO; SISTEMA ERMETICAMENTE SIGILLATO CONTAINS FLUORINATED GREENHOUSE GASES COVERED BY THE KYOTO PROTOCOL; SYSTEM HERMETICALLY SEALED</small>					

1	Identification of the company responsible for the product	16	Electrical resistance absorption
2	Conformity marking	17	Nominal power at normal operation
3	Type	18	Power in defrosting
4	Model name	19	Minimum pressure
5	Article	20	Maximum pressure
6	Manufacturing Date	21	Safety class
7	Production order	22	Nominal current
8	Customer order	23	Defrost current
9	Product class	24	Shelf load
10	Serial number	25	Tank loading
11	Owner registration number	26	Type of coolant
12	Power supply voltage	27	Weight of coolant
13	Power supply frequency	28	Gross volume
14	Fuse Value	29	Expanding isolation agent
15	Lamp Power	30	WEEE mark

5. COMPOSITION

The appliance consists of a single cabinet, on which are installed all the devices necessary to make it a product that is professional and efficient for its declared use.

The appliance consists of:

.....
A cooling system with ventilated refrigeration

.....
Condenser unit on board

.....
Electrical system

.....
Electronic command panel

.....
Insulated monolithic structure in ecological polyurethane

.....
Height-adjustable shelves

.....
Height-adjustable feet

.....
Door locking with key

6. USE

This equipment, based on the specific model, is used exclusively for the preservation of:

.....
TB ICE CREAM - CHILLED - FROZEN PRODUCTS

.....
The manufacturer is not liable for injury to persons or damage to property or the appliance itself caused by the displaying of products other than those described above.

THE APPLIANCE IS INTENDED FOR PROFESSIONAL USE



Non-permitted uses:

- Displaying and/or preserving of non-food products (chemicals, pharmaceuticals, etc.).

7. LOAD LIMITS

This appliance is exclusively intended for:



ATTENTION

It is fundamental not to exceed the load limits indicated in order not to alter the correct air circulation and thus to prevent a high product temperature. The limits indicated refer to a static and evenly distributed load. Therefore dynamic overloads due to violent loading operations are excluded, which must be prevented for safety reasons.



8. SAFETY

The appliance is equipped with safety devices. The buyer is responsible for training personnel using the appliance on the risks, safety devices and general health and safety rules required by the laws of the country where the appliance is installed. Users/operators must be aware of the position of all the controls and how they work, as well as of the features of the appliance. They should also read this manual in its entirety.

8.1 SAFETY DEVICES INSTALLED

Devices whose operation prevents the occurrence of risk situations in operating conditions (e.g. fuses, pressure switches, protections, magnet circuit breakers, etc.).

8.2 FIXED GUARDS

Fixed protective devices consist of fixed perimeter guards, which are used to prevent external parts from entering the equipment.



DANGER

It is prohibited to re-start the appliance following maintenance without having correctly restored the panels.



VISUAL OBSERVATION

Periodically check the integrity of the fixed guards and the relative fixings to the structure with particular attention to the protection panels.

8.3 ISOLATING THE ELECTRIC POWER SUPPLY

Before conducting any maintenance work on the equipment or on its parts, it is necessary to section the relevant power supply.



DANGER

In the event of maintenance operations where the operator cannot prevent accidental closure of the circuit by others, completely disconnect the appliance from the mains electricity.

8.4 CIRCUIT FAULTS

Owing to potential faults, safety circuits may become less effective, which results in lower safety levels. You should check the operational condition of the appliance devices regularly.

8.5 WARNING SIGNS (IF ANY)

The equipment is equipped with danger, attention and obligation warning plates defined in accordance with the legislation on graphic symbols to be used on the systems. The plates are located where they are clearly visible.



ATTENTION

Any warning plates on the appliance must not be removed.

The user is responsible for replacing warning signs that, owing to wear, become unreadable.

8.6 FALLING OBJECTS

Positioning of the cabinet display parts (where present) of the equipment (i.e. counters, rods and hooks, etc.), as well as the arrangement of the products inside the cabinet can be the source of potential hazards if not properly performed. Follow the positioning instructions described in this Manual before you place products inside the cabinet, check that the counters are properly fastened, as also the hooks, etc. Do not exceed the maximum load limit. Do not exceed the maximum load limit. Do not position tilted product on the counters if they are not held in place by their stoppers.

8.7 COOLING

During different operations to perform on the counter, such as cleaning or loading goods, it is necessary to handle products and/or counter parts at a low temperature with the risk of "cold injury" for the operators and/or accidental slipping hazard. Follow the safety regulations in the place where the cabinet is installed; more specifically, be sure to always use correct PPE (especially gloves).

8.8 FOOD SAFETY (PACKAGED PRODUCTS)

Refrigerator cabinet described herein is meant to be used to display packaged products. As such, it is not designed for direct contact between the foodstuffs and display surfaces. If the foodstuffs do accidentally make contact with the surfaces and for a rather long time, the product may become contaminated. Follow the guidelines on how to use the cabinet. If a product package breaks, remove it from the cabinet and clean, if necessary.

9. RESIDUAL RISKS

During design the manufacturer examined all the areas or parts at risk. Therefore, all necessary precautions have been taken to prevent risks to persons and damage to the appliance.



ATTENTION

Periodically check that all safety devices are operating correctly.
Do not remove the fixed guards.
Do not introduce unauthorised objects or tools into the work area.

Although the appliance is fitted with the safety devices prepared, there are still some risks that cannot be eliminated, but reduced via corrective actions by the final integrator and correct operational procedures. Below is a summary of the remaining risks associated with the appliance during:

Normal operation.
Adjustments and fine-tuning.
Maintenance.
Cleaning.

9.1 RISK OF CONTACT WITH LIVE PARTS

Risk of breaking or damaging the electrical components of the appliance, with a possible reduction in safety levels following a short circuit. Before connecting the electricity supply, make sure there is no ongoing maintenance work.



ATTENTION

Before carrying out the connection, check that the d.c. current in the installation point does not exceed the value indicated on the protections switches present in the electric control board. If this is not the case, the user must provide the relevant limiting devices.

It is strictly forbidden to conduct any electrical modification, in order to prevent additional unforeseen hazards and risks.

9.2 FIRE



DANGER

In the event of a fire, immediately disconnect the master switch from the main power supply line.

9.3 EXPLOSIVE ATMOSPHERE

The equipment must not be located in an area classified as an explosion risk according to 1999/92/EC such as:

Zone 0

An area in which there is a permanent, long-lasting or frequently explosive atmosphere made up of a mixture of air and flammable substances in the form of gases, fumes or steam.

Zone 1

An area in which the formation of an explosive atmosphere, made up of a mixture of air and flammable substances in the form of gases, fumes or steam is occasionally probable during normal activities.

Zone 20

An area in which there is a permanent, long-lasting or frequently explosive atmosphere in the form of clouds of combustible dust in the air.

Zone 21

An area in which the formation of an explosive atmosphere in the form of clouds of combustible dust is occasionally probable during normal activities.

9.4 SLIPPING



DANGER

Any leaks in the areas surrounding the appliance may cause personnel to slip. Check that there are no leaks and keep these areas clean at all times.

9.5 TRIPPING



DANGER

Generally, untidy deposits of material may constitute a tripping hazard and a total or partial obstruction of emergency exit routes. Ensure operational, transit and escape routes, free from obstacles, and comply with the current regulations.

10. DISPOSAL OF WASTE MATERIAL

During normal operation, the appliance does not generate any environmental contamination. At the end of its life cycle, or if it is necessary to proceed to permanent decommissioning, we recommend following the procedures below:

DISPOSAL (USER)



The symbol, applied to either the product or its packaging, indicates that the product should not be considered as normal domestic waste, but should be taken to a waste collection point for the recycling of electrical and electronic appliances. The correct disposal of this product contributes to preventing potential negative consequences that might derive from an inadequate disposal of the product. For detailed information about recycling this product, contact your council, your local waste collection service or the store where you purchased the product.

PROCEDURE FOR DISPOSAL and RECYCLING AT THE END OF APPLIANCE LIFE CYCLE (AUTHORISED BODIES)

- Switch off the equipment and unplug the power supply cable.
- Remove the lamps (if installed). These should be disposed of separately.
- Remove the power supply units and the electronic cards. These must be disposed of separately.
- Disassemble all the independent parts (grids, casings, profiles, etc.) and separate them by homogeneous material characteristics, in order to access the heat exchangers, pipes, cables, etc. being careful not to damage the refrigeration circuit.
- Remove all mobile parts (doors, sliding doors, glass parts, etc.) and group the various materials according to their similar features.
- Check the type of refrigerant on the plate inside the counter; remove the refrigerant and dispose of it through the authorised services.
- Disconnect the evaporator, condenser, compressor, pipes and fans; the tubes being made of copper, aluminium, steel and plastic must be disposed of separately.
- After removing all the casings and the various components from the frame, separate the different types of material that compose them (plastic, sheet metal, polyurethane, copper, etc.) and group by homogeneous characteristics.



All recyclable materials and waste should be processed and recycled by professionals, in compliance with the laws in the country in question. The company assigned to recycling must be registered and certified as a waste disposal service according to the specific directives of the country in question.

ATTENTION



Illegal disposal of the product by the owner will result in the application of administrative sanctions provided by the laws in force. Disposal of the product should comply with current laws on the disposal of coolant liquids and mineral oils.

IMPORTANT



If the crossed out wheeled bin symbol is not present on the equipment, it means that disposal of the product itself is not the responsibility of the manufacturer; in this case the regulations in force on waste disposal, of the municipal office, of the local waste disposal service or of the shop where the product was purchased always apply

ADDITIONAL INFORMATION



Further information on how to dispose of coolant and oils and other substances can be found on the safety data sheet of the substances themselves. To dispose of foamed assemblies, remember that the polyurethane foams used are CFC-, HFC- and HCFC-free.

11. INSTALLATION

11.1 UNPACKING

All packaging materials are recyclable and should be disposed of in accordance with local regulations. All packaging materials are recyclable and should be disposed of in accordance with the local regulations. Please destroy "plastic" bags to prevent them from becoming hazardous to children (suffocation).

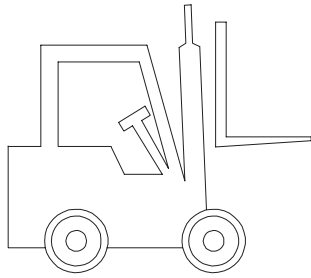

1

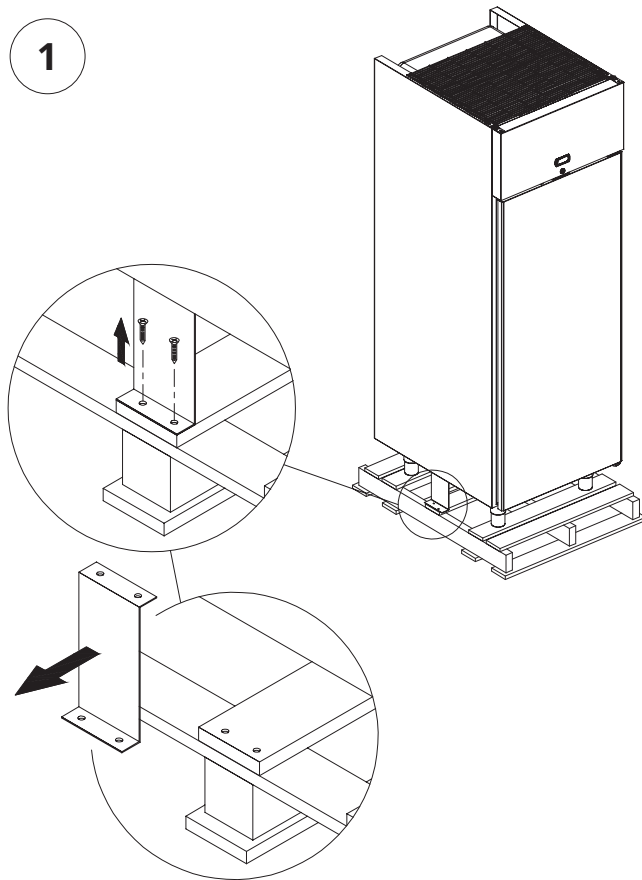

11.1 UNPACKING

2

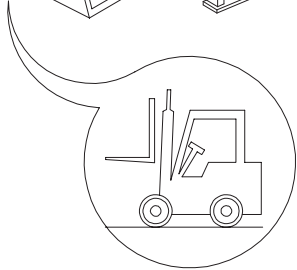
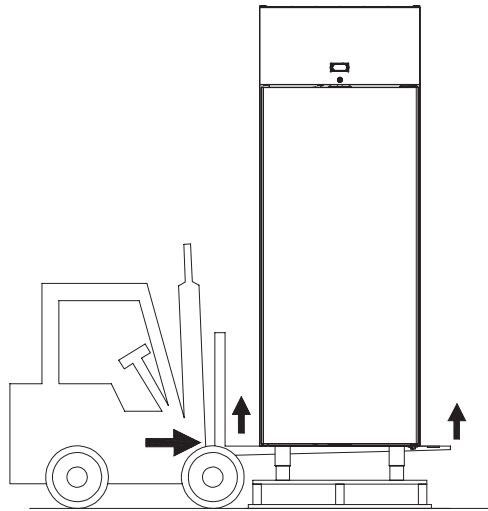
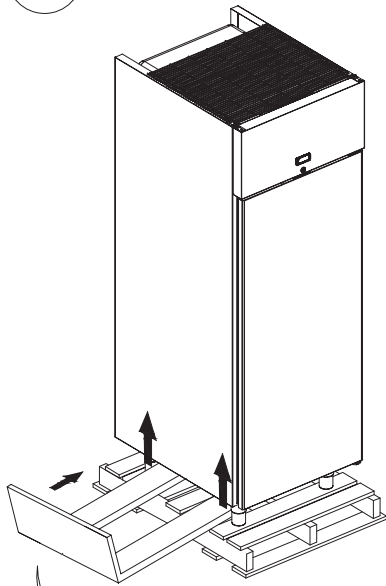

	Min.	Max
A	-	-
B	-	500
H	60	

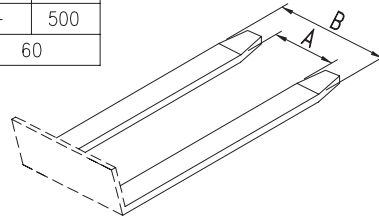

3

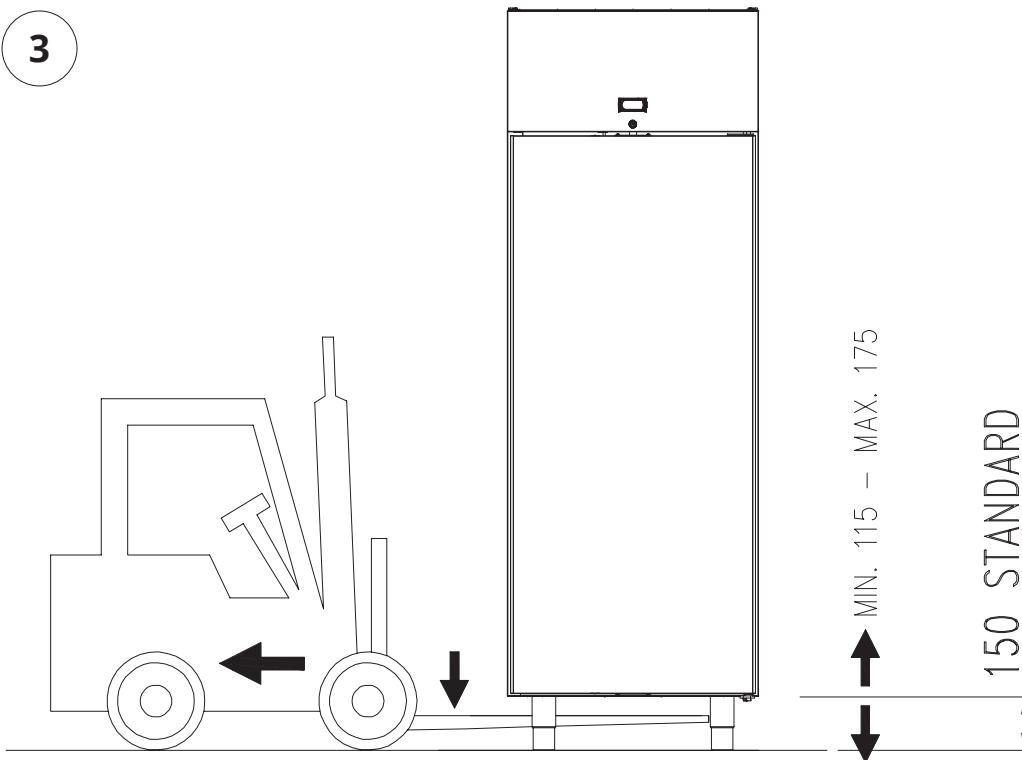

11.2 HANDLING



Handling of the equipment must be performed exclusively by a forklift truck of power adequate to the weight of the same and operated by qualified personnel: during this operation the equipment must always be positioned on the dedicated pallet supplied.

11.3 STORAGE

The appliance, with or without its packaging, must be carefully stored inside warehouses or in areas protected from the weather and from direct sunlight, at a temperature of between 0 and +40°C.



+40 °C MAX

0 °C MIN

11.4 ENVIRONMENTAL CONDITIONS



ATTENTION

A dry room that can be ventilated is the suitable location for the appliance's installation. There should be a good air flow around the compressor/condensing unit. Therefore the area around the unit should not be obstructed by boxes or other objects. Place the equipment away from sources of heat (radiators, heaters of any kind, etc.) and far from the influence of continuous air movement (caused by fans, air conditioning units, etc.). If it is unavoidable to install near a heat source, use a suitable insulating plate. Also avoid exposure to direct solar irradiation; all of this causes the temperature inside the refrigerated compartment to rise with negative consequences on operation and energy consumption. Do not use the appliance outdoors and do not leave it exposed to rain.

11.5 ELECTRICAL CONNECTION



ATTENTION

Check that the network voltage matches the one displayed on the identification plate of the appliance, and that the power is adequate. Check on the socket that the power supply voltage provides rated voltage ($\pm 10\%$) when you start up the compressor. The plug should be directly connected to the electrical socket. It is forbidden to connect the plug to the socket by means of multiple socket extensions or adaptors. The plant power supply socket must be fitted with a disconnection device from the mains electricity (dimensioned to the load and in compliance with Standards in force), which guarantees complete disconnection in category III (3) over-voltage conditions and therefore protects the circuits against earth faults, overloads and short circuits. Do not route the electricity cable in passageways.



ATTENTION

Remember that **earthing** is necessary and **is a requirement imposed by law**.

11.6 WALL MOUNTING



ATTENTION

It is fundamental to respect the distances indicated (mm) for correct installation of the appliance.

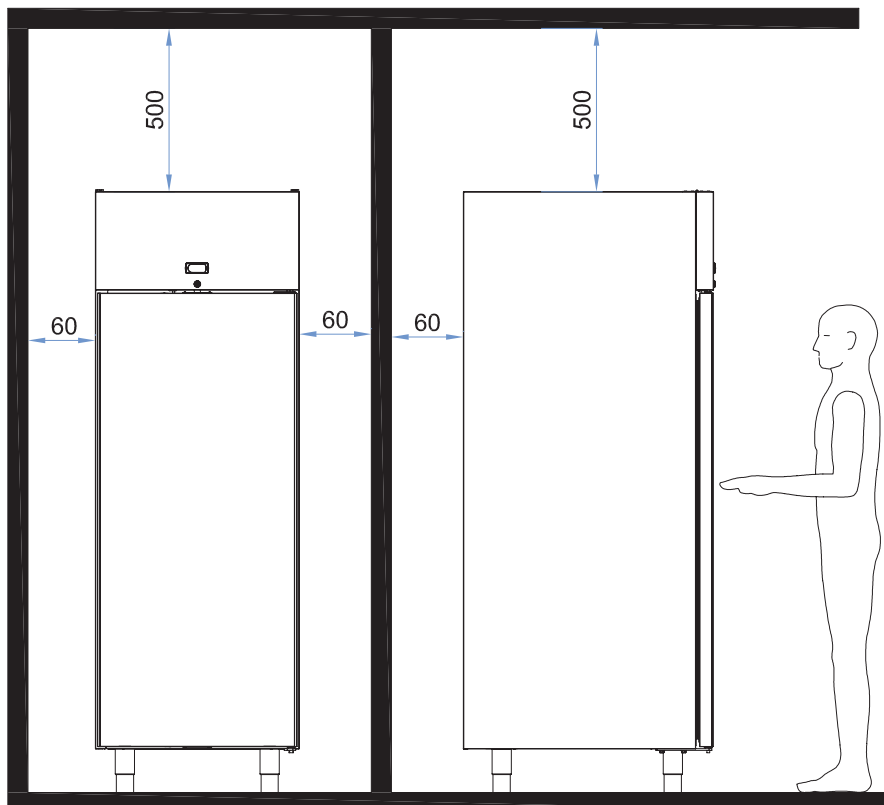

11.7 LEVELLING



ATTENTION

The equipment is fitted with height-adjustable levelling feet; after positioning, it is **absolutely essential to level the equipment** on the floor.

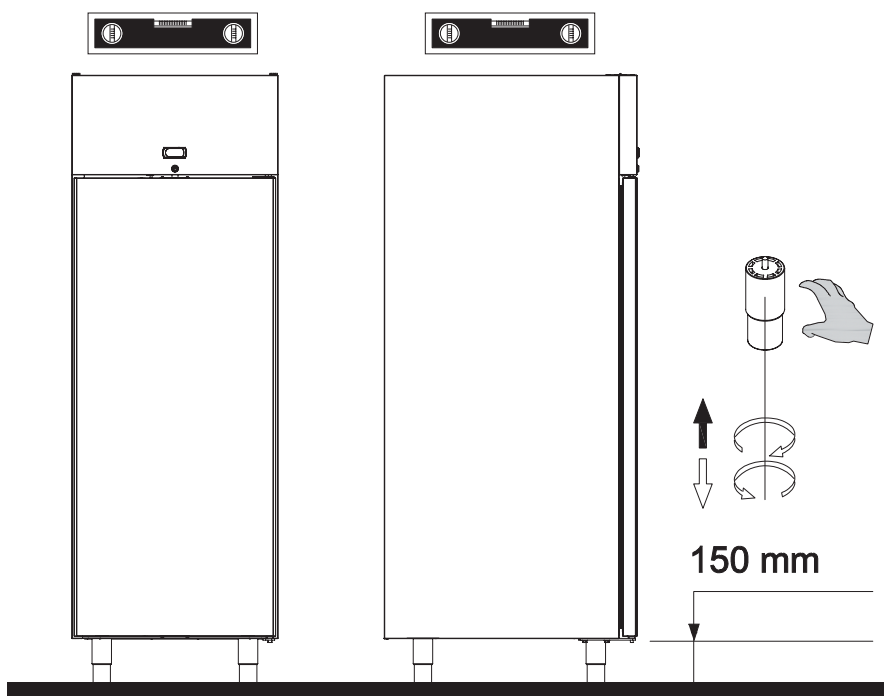

12. MAINTENANCE

The **Staff in charge of the appliance** must control and respect the expiry dates for maintenance, given in the table below, contacting the authorised **Technical Assistance** when indicated.

OPERATION	FREQUENCY					EXTRAORDINARY	PERSONNEL AUTHORISED
	According to Use and Requirement	Monthly	Every 6 months	Annual	ORDINARY		
CLEAN THE EXTERNAL SURFACES	●				●		USER
CLEAN THE ACCESSIBLE INTERNAL PARTS (without the use of tools)	●				●		
CONTROL OF POWER SUPPLY CABLE, PLUGS AND/OR ELECTRICAL OUTLETS			●		●		
CHECK THE INTEGRITY OF THE SEALS		●			●		
CLEAN THE CONDENSING UNIT FILTER (whenever present)			●		●		
CLEAN THE DEFROSTING WATER COLLECTION TRAY	●				●		TECHNICAL ASSISTANCE 
CLEANING OF WASHING WATER COLLECTION TRAY (Inside of tray - where present)	●				●		
CONDENSER CLEANING	●			●	●		
CHECK COMPRESSOR OIL LEVEL (whenever present)					●		
AIR TANK DRAINING (whenever present)			●		●		
CONTROL PNEUMATIC CONNECTIONS (whenever present)			●		●		
CHECK THE INTEGRITY OF THE COOLING SYSTEM PIPES			●		●		
INSPECT THE CABLES AND INTERNAL POWER CONNECTIONS			●		●		
CLEAN THE CONDENSATE DRYING SPONGES (whenever present)			●		●		
LAMP / LED REPLACEMENT (whenever present)						●	
REPLACE THE CONTROL PANEL (electronic control unit - thermostat - etc.)						●	
REPLACE THE POWER SUPPLY CABLE, PLUGS AND/OR ELECTRICAL SOCKETS						●	

ATTENTION



After all maintenance it is **mandatory** to perform all electrical safety tests in accordance with the IEC EN 50106 Standard.

13. FAULTS - TECHNICAL AFTER-SALES ASSISTANCE

If the appliance is not working properly or stops working, before contacting the **Customer Support Centre** check the following:

USER

	CAUSE	SOLUTION
THE EQUIPMENT DOES NOT WORK	Blown protective fuse	First find the cause of the trip of the switch, and then replace the new fuse.
	The master switch is open	Close the master switch.
	The plug is not inserted	Insert the plug.
	Electrical black-out	If the black-out should be prolonged, transfer the product into an appropriate cold storage container.
THE TEMPERATURE IS NOT SUFFICIENTLY LOW	Evaporator(s) completely blocked with ice	Carry out an additional defrosting cycle.
	Wrong temperature setting	Set the appropriate temperature.
	Equipment being struck by currents of air or exposed to direct or reflected sunlight	Remove any draughts and prevent any direct or reflected sunlight.
	Insufficient air flow for cooling to the condenser	Remove anything which could obstruct the circulation of air through the condenser (sheets of paper, cardboard, insufficient slots in grille, etc.).
THE COMPRESSOR DOES NOT START WORKING OR WORKS FOR VERY SHORT PERIODS	No electric power supply to the appliance	Check if there is a power cut. Close the various switches on the power supply line.
	Excessively low power voltage	Check that the mains voltage of the power supply cable corresponds to the nominal value 220V +/- 10%.
	Temperature set too high	If the temperature is higher than the air temperature in the display chamber, the compressor will not start. Set the suited temperature if the current temperature is not low enough.

TECHNICAL ASSISTANCE



	CAUSE	SOLUTION
THE TEMPERATURE IS NOT SUFFICIENTLY LOW	Internal ventilators not working or damaged fans	Replace the ventilators/fans.
	Thermostat / Electronic control board not efficient	Replace the thermostat/electronic control board. If the electronic control board is used on appliances with R290 coolant, it must only be replaced with an original spare part supplied by the manufacturer. Replace the temperature probes only after having ascertained which of them is inefficient.
	Condensing unit blocked with dust or dirt in general	Clean the condensing unit thoroughly. The condensing unit in particular operating environments (e.g. presence of dust, presence of excessive humidity, etc.) when the performance of the appliance deteriorates requires careful cleaning.
	Insufficient refrigerant load in the cooling system	Find the cause of the refrigerant loss and remove it; top up the refrigerant load if necessary having emptied the system.
THE COMPRESSOR DOES NOT START WORKING OR WORKS FOR VERY SHORT PERIODS	Maximum pressure switch triggered (if present)	Check the reasons why the pressure switch is operating at maximum pressure levels, such as: air condenser obstructed, condenser fan with air stopped, ambient temperature too high, pressure switch defective.

14. TECHNICAL SPECIFICATIONS

Model	External dimensions (mm)			Weight (kg)
	Length	Depth	Height	Net
700	710	951	2090	135

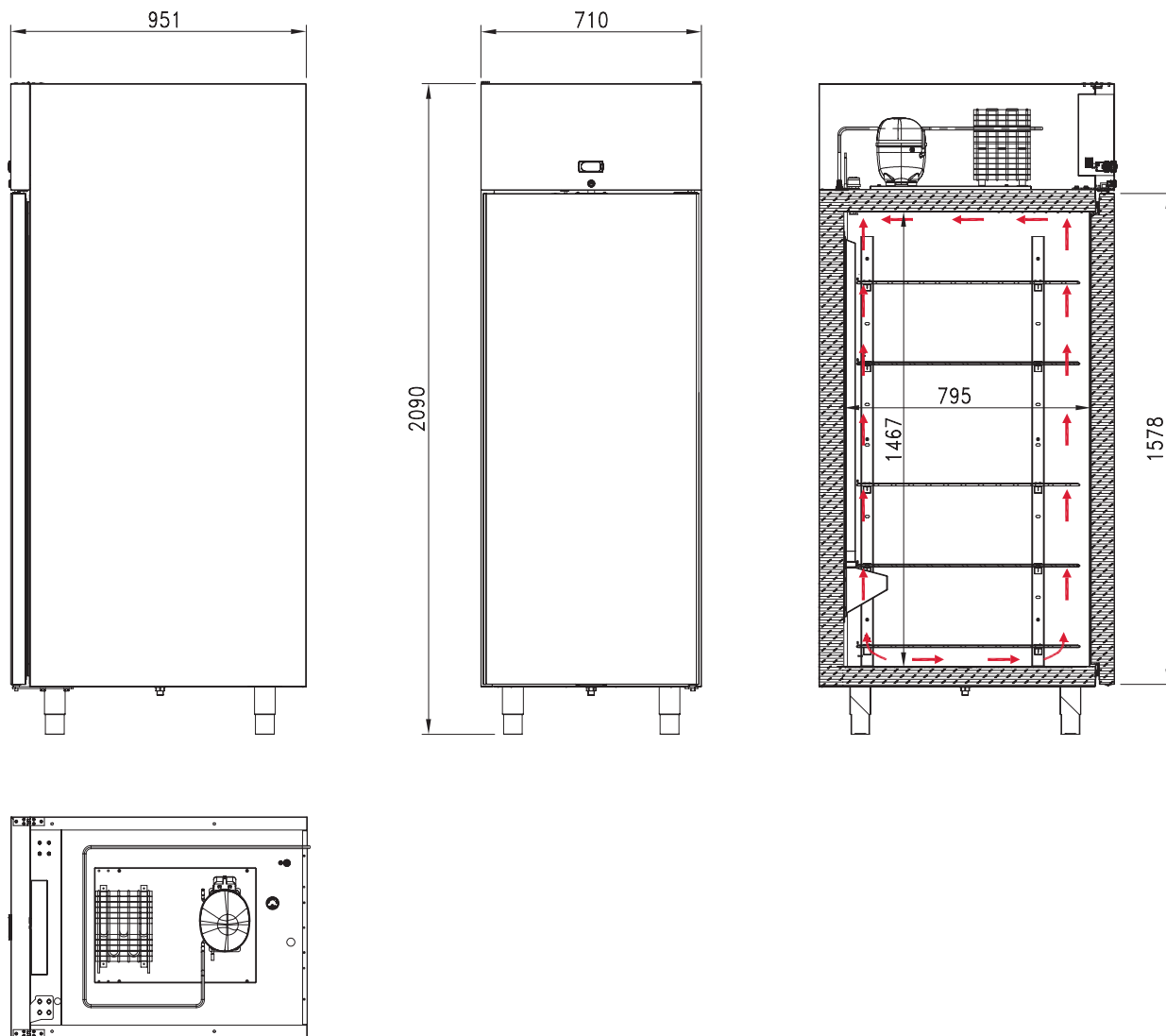

14.1 SHELF LOADS



ATTENTION

It is **absolutely essential** to observe the max loads indicated.

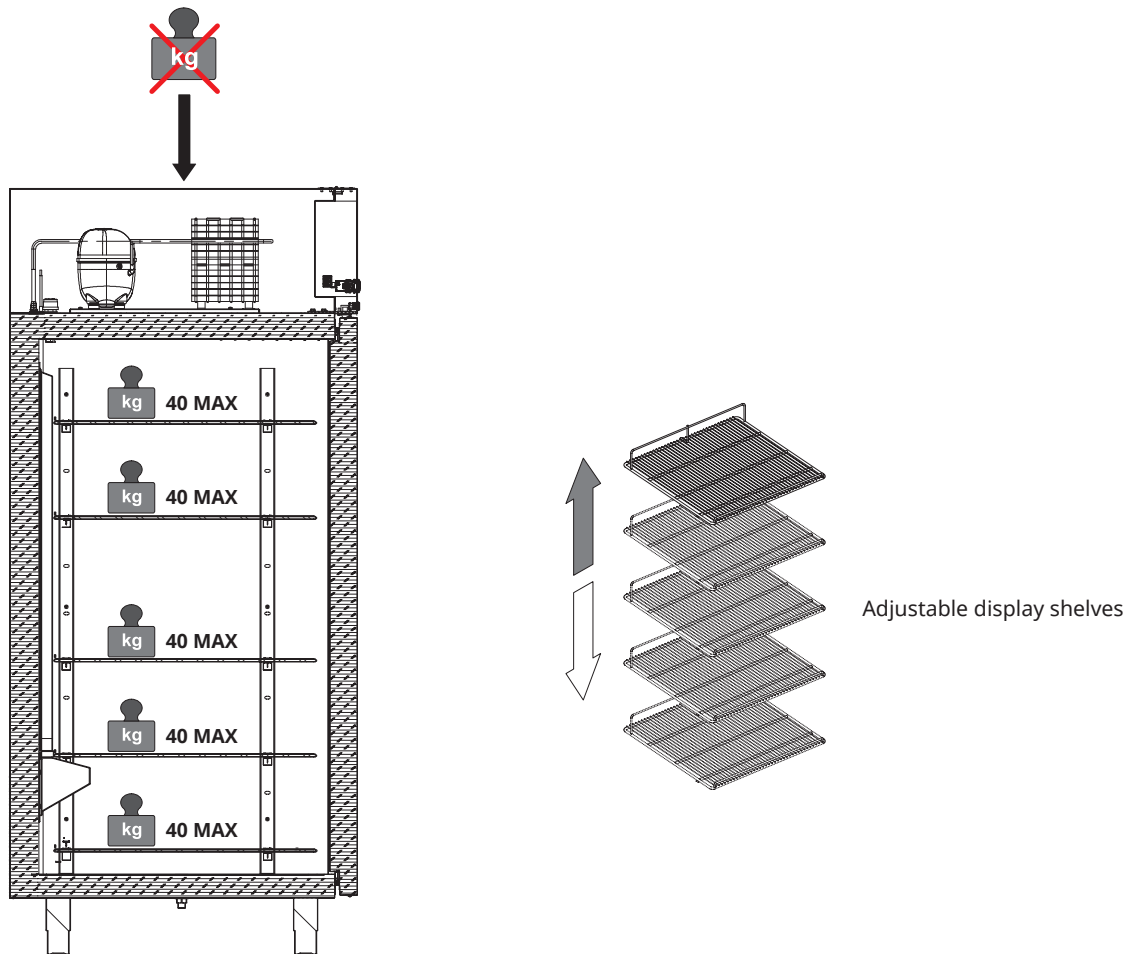

14.2 CLOSURE WITH KEY



ATTENTION

The appliance is equipped with a lock with key for closing of the door as indicated. Retain and store the key out of the reach of children.



15. CONTROL PANEL

START-UP (ON)

Activate the mains system master switch.
Insert the power plug on the socket provided by the customer, making sure that the same has an earth contact and that there are no multiple sockets connected.

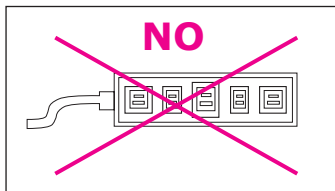
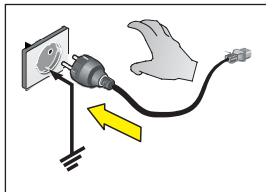

The appliance will start working automatically

SWITCH OFF (OFF)

Remove the power plug manually.

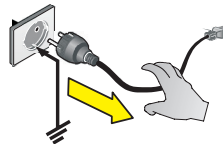

ATTENTION



The electronic control unit is installed already programmed; any changes to the control unit settings can only be performed by qualified technical personnel.





KEY(S)

-
- 

UP
Press and release
 Scrolls menu options.
 Increases the values.
 - 

MANUAL ACTIVATION OF THE DEFROSTING CYCLE
 Press for more than 5 seconds; if there are no conditions for defrosting (for example the evaporator probe temperature is higher than the end of defrosting temperature) the display will flash three (3) times to indicate that the operation will not be performed.

 - 

DOWN
Press and release
 Scrolls menu options.
 Decreases the values.
 - 

MANUAL ACTIVATION OF THE DEFROSTING CYCLE
 Press for more than 5 seconds; if there are no conditions for defrosting (for example the evaporator probe temperature is higher than the end of defrosting temperature) the display will flash three (3) times to indicate that the operation will not be performed.

 - 

STAND-BY (ESC)
Press and release
 Goes back up one level with respect to current menu.
 Confirms parameter value.
 Activates the Stand-by function.
 - 

INSTRUMENT ON/OFF
 Press for more than 5 seconds to switch off the instrument; in this condition the settings and defrost are disabled and the display will show the word "OFF".

 - 

SET (ENTER)
Press and release
 Display alarms (if any).
 Access the Machine Status menu.
Press for over 5 seconds
 Access the Programming menu.
 Confirm the data.
 - 

SETTING SET POINT
 - 





By pressing and releasing the **SET** button, it is possible to access the "Machine Status" menu; if there are no alarms in progress, the "Set" label will be displayed.
 To view the Set Point value, press the button again; to change the value, press the **UP** or **DOWN** buttons within 15 seconds.
 To confirm the new value, press the **SET** button again.

 **ATTENTION**
 When the instrument is turned on, it performs a **Lamp Test** for a few seconds; the display and the LEDs flash with verification of the integrity and correct functioning of the same.

15.1 USER INTERFACE



LED

	ON (Steady)	FLASHING	OFF
	Compressor active	Delay, protection or activation blocked.	Other
	Defrosting in progress	Activation manually or from D.I.	Other
	Fans active	/	Other
	Energy-saving active	Reduced set active Access to level 2 parameters (Quick flashing)	Other
	Presence of alarm	Alarm silenced	Other
°F	Setting in °F (dro = 1)	/	Other
AUX	Aux Output active	Deep Cooling cycle active	Aux Output not active
°C	Setting in °C (dro = 0)	/	Other

ALARMS

	FAULT	CAUSE
E1	Probe 1	Reading of values outside the operating range Probe faulty / Short-circuited / Open.
E2	Probe 2 (Defrost)	Reading of values outside the operating range Probe faulty / Short-circuited / Open.
AH1	HIGH Temperature Alarm Pb1	Value read by Pb1 > HAL after time of tAO.
AL1	LOW Temperature Alarm Pb1	Value read by Pb1 < LAL after time of tAO.
EA	External Alarm	Activation of digital input (H11 = ±5)
OPd	Alarm Door Open	Activation of the digital input (H11 = ±4) for a time greater than tdO
Ad2	End of defrost due to Time-Out	End of defrost by time instead of reaching the end of defrost temperature detected by Pb2.

16. CLEANING

The materials listed below must be cleaned as follows:

STAINLESS STEEL	Only use warm water and non-aggressive detergents and then rinse.
ACRYLIC / POLYCARBONATE	Wash with lukewarm water, using a soft cloth or a chamois cloth.
CURVED GLASS	Only use products specifically designed for cleaning glass. It is advisable not to use tap water which could leave limescale residues.

16.1 INTERNAL



ATTENTION

Do not scrape ice from the walls with pointed tools, the surface could be damaged.
Do not use high pressure appliances (e.g. steam generators).

- 1 Remove the product contained in the refrigerated compartment and place it immediately in a suitable refrigerated container to ensure proper storage.



- 2 Turn off the equipment.

- 3 Wait at least 4 or 6 hours for any ice on the evaporator to melt completely, before proceeding with cleaning of the appliance. It is advisable, in this regard, to wait until the following day to make sure that the defrost has been fully performed. Do not use mechanical devices or other means to accelerate the defrosting process other than those recommended by the manufacturer.

- 4 Remove the manually removable accessories (e.g. slides, grids, bottom shelves, ice-cream trays, etc.).

- 5 Remove the drain plug of the tank bottom (mod. **RS TB**) located below the bottom shelf) to allow the water to flow into the dedicated tray located inside the base with the equipment. Proceed to also clean and disinfect the collection tray.



ATTENTION

Ensure, for operation of the appliance, **correct and complete re-insertion of the drain plug** after cleaning.

- 6 Clean the side walls and the bottom of the tank using a non-aggressive detergent, lukewarm water and a non-abrasive cloth or sponge. Do not use sharp tools. Rinse thoroughly and dry with an absorbent cloth.

- 7 Refit the accessories previously removed.

- 8 Switch on the appliance and allow the counter to cool down until it reaches the desired temperature before reintroducing the food.

16.2 CONDENSING UNIT

Turn off the equipment. Wait a few hours until every piece of equipment on the condenser unit has reached a temperature close to room temperature.

Access the Condenser Unit as indicated below.

Clean the condenser using a dedicated soft bristle brush; perform the operation taking care not to bend the condenser plates.

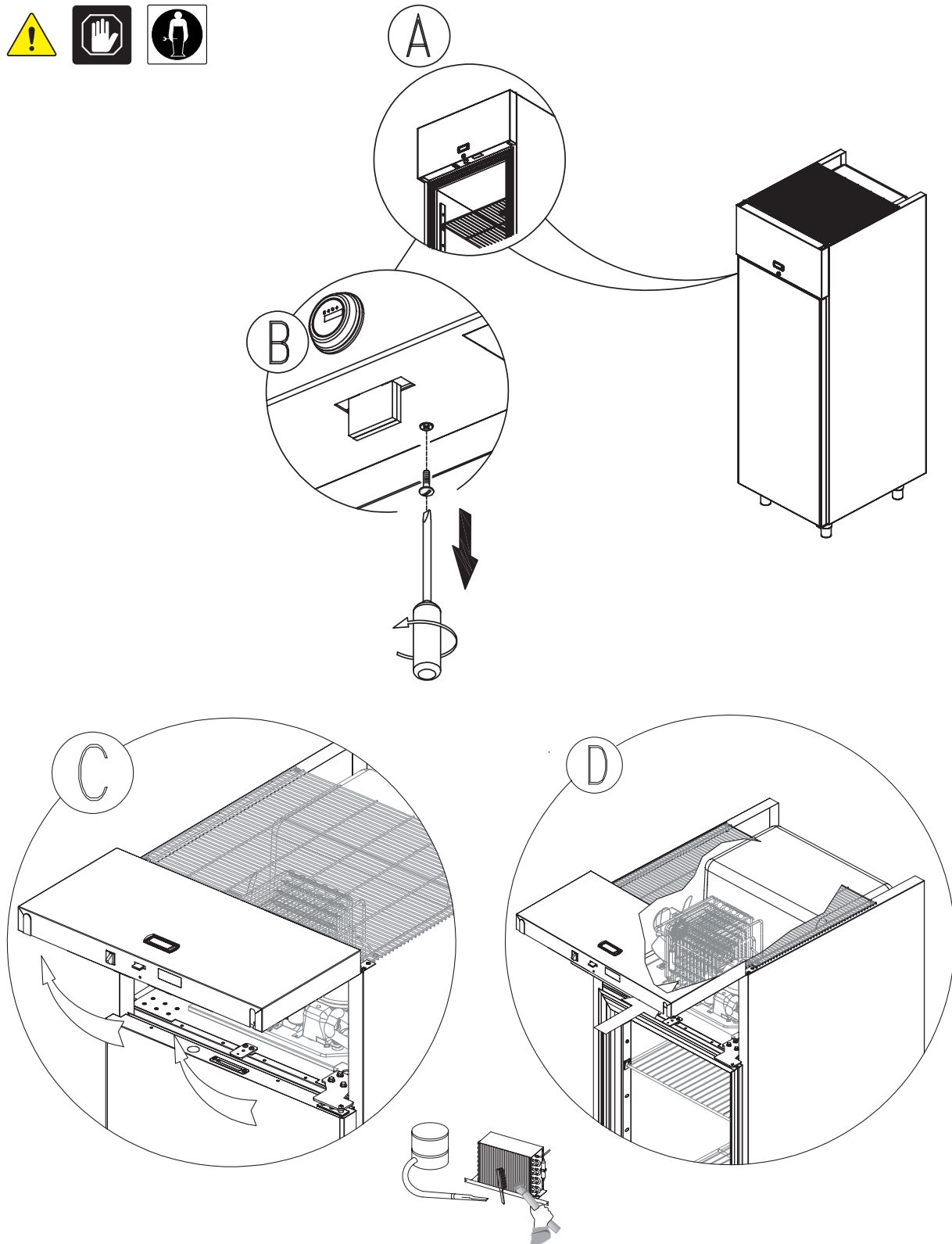

16.3 DEFROST WATER COLLECTION TRAY (IF PRESENT)

Clean based on use and as needed and in certain environmental conditions (e.g., high humidity, low environmental temperature, presence of dust, etc.) in order to avoid the incorrect and complete evaporation of the water and/or the presence of unpleasant odours. **Disinfect** the tray with suitable products.

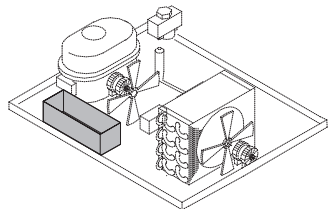

17. PROLONGED APPLIANCE SWITCH-OFF

Remove the product contained in the refrigerated compartment and place it immediately in a suitable refrigerated container to ensure proper storage.

Open the equipment and wait for it to reach room temperature and then clean it.

Leave the door/sliding panels open by 2-3 cm so as to guarantee circulation of the air and prevent the formation of mould and bad smells inside the appliance.

The appliance, with or without its packaging, should be carefully stored inside warehouses or in areas protected from the weather and from direct sunlight, at a temperature of between 0 and +40°C.

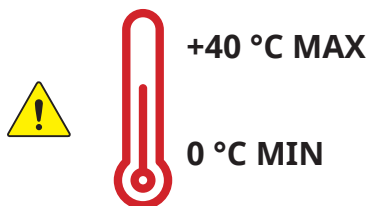

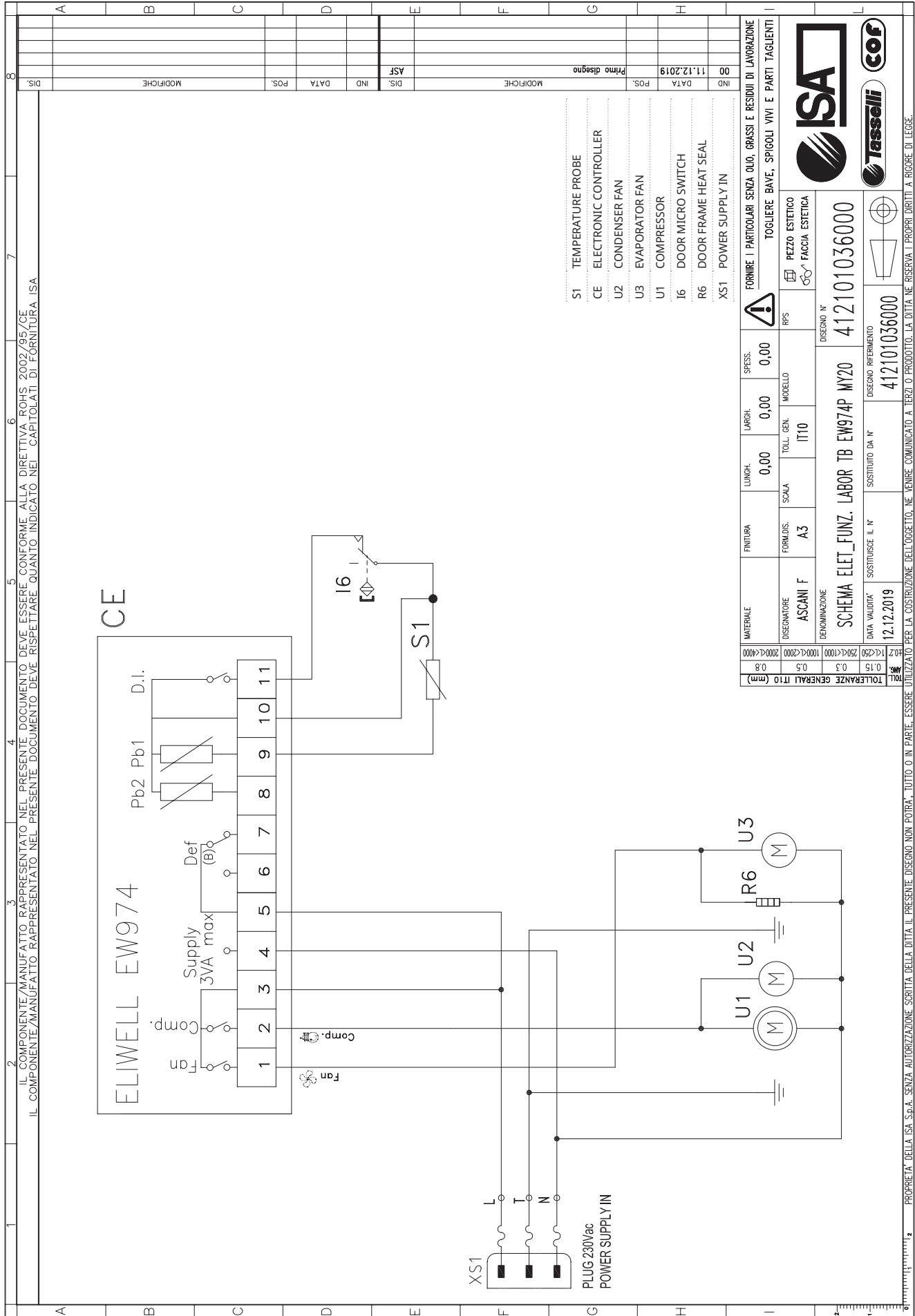

WIRING DIAGRAM

IND	00	DATA	11.12.2019	POS.	Primo disegno	MODIFICHE	
DIS.		IND		DATA		MODIFICHE	
POS.		DIS.		IND		MODIFICHE	
DATA		POS.		DATA		MODIFICHE	
IND		DIS.		IND		MODIFICHE	
DIS.		POS.		DATA		MODIFICHE	

MATERIALE	FINITURA	LUNGH.	LARGH.	SPESS.	FORME	TOGLIERE BAVE, SPIGOLI VIVI E PARTI TAGLIANTI
		0,00	0,00	0,00		
TOSSIGRATORE	FORMULIS.	SCALA	TOLL. GEN.	MODELLO	RPS	PEZZO ESTETICO
ASCANI F	A3		IT10			FACCIA ESTETICA
DENOMINAZIONE						
SCHEMA ELET_FUNZ. LABOR TB EW974P MY20						
DISEGNO N°						
412101036000						
DATA VALIDITA'	SOSTITUISCE IL N°	SOSTITUITO DA N°	DISEGNO RIFERIMENTO			
12.12.2019			412101036000			
TOLLERANZE GENERALI IT10 (mm)						
0,2	0,15	0,3	0,5	0,8		
1 < 250	250 < 1000	1000 < 2000	2000 < 4000	4000 < 8000		

FORNIRE I PARTICOLARI SENZA OLIO, GRASSI E RESIDUI DI LAVORAZIONE						
TOGLIERE BAVE, SPIGOLI VIVI E PARTI TAGLIANTI						

ISA	Tasselli	COF
-----	----------	-----

PROPRIETA' DELLA ISA S.p.A. SENZA AUTORIZZAZIONE SCRITTA DELLA DITTA IL PRESENTE DISEGNO NON POTRA' TUTTO O IN PARTE, ESSERE UTILIZZATO PER LA COSTRUZIONE DELL'OGGETTO, NE' VENIRE COMUNICATO A TERZI O PRODOTTO. LA DITTA NE RISERVA I PROPRI DIRITTI A RICORDO DI LEGGE.

