

Kelly Lineare

H 117

P 80

L 100 • 125 • 150 • 175 • 200

Pastry • Chocolate • Snack • Food

Installation

Plug-in

Temperature

- +4/+8 °C (TN)
- +14/+16 °C (CH)
- +65 /+80 °C (TCS)

Refrigerant

R290

Refrigeration

Ventilated

Compressor

Hermetic

Defrost

Off cycle

Climate class

3

Front glass

Extra clear single

Side glass

Extra clear single

Rear closing system

Glass sliding doors

Lighting

Led 3000 K

Base

Height adjustable feet

Color

White RAL 9003

Installazione

Plug-in

Temperatura

- +4/+8 °C (TN)
- +14/+16 °C (CH)
- +65 /+80 °C (TCS)

Refrigerante

R290

Refrigerazione

Ventilata

Compressore

Ermetico

Sbrinamento

Fermata compressore

Classe Climatica

3

Vetro frontale

Singolo extrachiaro

Vetri laterali

Singolo extrachiaro

Chiusura posteriore

Scorrevoli in vetro

Illuminazione

Led 3000 K

Basamento

Piedini regolabili in altezza

Colore

Bianco RAL 9003



R290

Kelly Lineare

100			125		
RV TN	RV CH	TCS	RV TN	RV CH	TCS

External dimensions (LxDxH) Dimensioni esterne (LxPxH)	H117	1000x819x1170 mm			1250x819x1170 mm		
Capacity (gross/net) Capacità (lorda/netta)	H117	-			-		
Net weight Peso netto	H117	-	-	-	-	-	-
Refrigeration Refrigerazione		Ventilated Ventilata			Ventilated Ventilata		
Refrigerant Refrigerante		R290			R290		
Climate class Classe climatica		3					
Operating conditions Condizioni ambientali		25 °C / 60 %RH					
Product temperature Temperatura prodotto		+4/+8 °C	+14/+16 °C	+65/+80 °C	+4/+8 °C	+14/+16 °C	+65/+80 °C
Compressor (q.ty - type) Compressore (q.tà - tipologia)		1 - Hermetic 1 - Ermetico			1 - Hermetic 1 - Ermetico		
Defrost Sbrinamento		Off Cycle Fermata compressore			Off Cycle Fermata compressore		
Power supply Alimentazione		230 V / 1 Ph / 50 Hz					
Electrical input (nominal) Assorbimento elettrico (regime)		411 W / 2,1 A	595 W / 2,7 A	740W / 3,6 A	418 W / 3 A	502 W / 2,7 A	930 W / 04,5 A
Electrical input (defrost) Assorbimento elettrico (sbrinamento)		242 W / 1,3 A			229 W / 1,3 A		

Technical sheet about models whit condensing unit included with air cooled
Dati tecnici riferiti a modelli con unità a bordo con condensazione ad aria

Setup

Allestimento

Bottom shelf (LxD) Ripiano di fondo (LxP)	1000 x 602 mm	1250 x 602 mm
---	---------------	---------------

150			175			200		
RV TN	RV CH	TCS	RV TN	RV CH	TCS	RV TN	RV CH	TCS

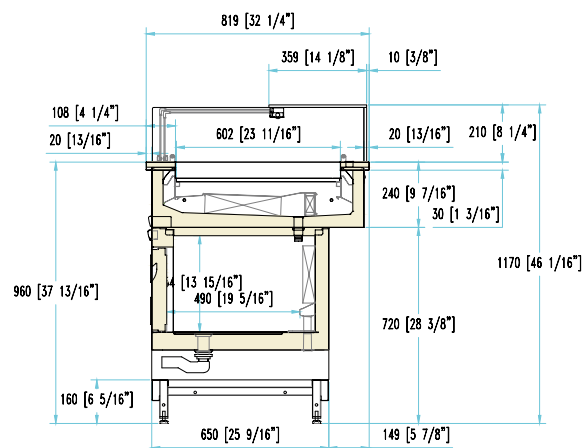

1500x819x1170 mm			1750x819x1170 mm			2000x819x1170 mm		
-			-			-		
-	-	-	-	-	-	-	-	-
Ventilated Ventilata			Ventilated Ventilata			Ventilated Ventilata		
R290			R290			R290		
3								
25 °C / 60 %RH								
+4/+8 °C	+14/+16 °C	+65/+80 °C	+4/+8 °C	+14/+16 °C	+65/+80 °C	+4/+8 °C	+14/+16 °C	+65/+80 °C
1 - Hermetic 1 - Ermetico			1 - Hermetic 1 - Ermetico			1 - Hermetic 1 - Ermetico		
Off Cycle Fermata compressore			Off Cycle Fermata compressore			Off Cycle Fermata compressore		
230 V / 1 Ph / 50 Hz								
498 W / 3 A	597 W / 3,2 A	1120 W / 5,4 A	504 W / 3,6 A	603 W / 3,3 A	1320 W / 6,4 A	567 W / 4,1 A	788 W / 4,3 A	1500 W / 7,2 A
307 W / 1,6 A			313 W / 1,7 A			450 W / 2,4 A		

1500 x 602 mm	1750 x 602 mm	2000 x 602 mm
---------------	---------------	---------------



Available colours - Colori disponibili

Front panel (1) - Side panels (2)
Pannello frontale (1) - Fianchi laterali (2)

-  RAL 9003
-  RAL on demand
- **Standard / Di serie**

Kelly Angolare

H 117
P 80
L 150 TDX • 150 TSX

Pastry • Chocolate • Snack • Food

<p>Installation Plug-in</p> <p>Temperature • +4/+8 °C (TN) • +14/+16 °C (CH) • +65 /+80 °C (TCS)</p> <p>Refrigerant R290</p> <p>Refrigeration Ventilata</p> <p>Compressor Hermetic</p> <p>Defrost Off cycle</p>	<p>Climate class 3</p> <p>Front glass Extra clear single</p> <p>Side glass Extra clear single</p> <p>Rear closing system Glass sliding doors</p> <p>Lighting Led 3000 K</p> <p>Base Heigh adjustable feet</p> <p>Color White RAL 9003</p>	<p>Installazione Plug-in</p> <p>Temperatura • +4/+8 °C (TN) • +14/+16 °C (CH) • +65 /+80 °C (TCS)</p> <p>Refrigerante R290</p> <p>Refrigerazione Ventilata</p> <p>Compressore Ermetico</p> <p>Sbrinamento Fermata compressore</p>	<p>Classe Climatica 3</p> <p>Vetro frontale Singolo extrachiaro</p> <p>Vetri laterali Singolo extrachiaro</p> <p>Chiusura posteriore Scorrevoli in vetro</p> <p>Illuminazione Led 3000 K</p> <p>Basamento Piedini regolabili in altezza</p> <p>Colore Bianco RAL 9003</p>
---	--	---	--



Kelly Angolare

	TDX			TSX		
	RV TN	RV CH	RV TN / TCS	RV TN	RV CH	RV TN / TCS
External dimensions (LxDxH) Dimensioni esterne (LxPxH)	H117 1500x819x1170 mm			1500x819x1170 mm		
Capacity (gross/net) Capacità (lorda/netta)	H117 -			-		
Net weight Peso netto	H117 210 kg			215 kg		
Refrigeration Refrigerazione	Ventilated Ventilata		-	Ventilated Ventilata		-
Refrigerant Refrigerante	R290			R290		
Climate class Classe climatica	3					
Operating conditions Condizioni ambientali	25 °C / 60 %RH					
Product temperature Temperatura prodotto	+4/+8 °C	+14/+16 °C	+65/+80 °C	+4/+8 °C	+14/+16 °C	+65/+80 °C
Compressor (q.ty - type) Compressore (q.tà - tipologia)	1 - Hermetic 1 - Ermetico		-	1 - Hermetic 1 - Ermetico		-
Defrost Sbrinamento	Off Cycle Fermata compressore		-	Off Cycle Fermata compressore		-
Power supply Alimentazione	230 V / 1 Ph / 50 Hz					
Electrical input (nominal) Assorbimento elettrico (regime)	418 W / 3 A	502 W / 2,7 A	930 W / 04,5 A	418 W / 3 A	502 W / 2,7 A	930 W / 04,5 A
Electrical input (defrost) Assorbimento elettrico (sbrinamento)	229 W / 1,3 A		-	229 W / 1,3 A		-

Technical sheet about models whit condensing unit included with air cooled
Dati tecnici riferiti a modelli con unità a bordo con condensazione ad aria

Setup Allestimento

Bottom shelf (LxD) Ripiano di fondo (LxP)	1400 x 602 mm	1400 x 602 mm
---	---------------	---------------