

ISA S.p.A.

Via del Lavoro, 5
06083 Bastia Umbra
Tel. +39 075 80171
Fax +39 075 8000900
Perugia - ITALY
www.isaitaly.com



i aniaeci nothing will ever be the same

i Ghiacci, a new definition of space

I Ghiacci is the Isa's latest definition of commercial interior design that incorporates a new way of displaying merchandise. The gently curving lines and the decidedly different structure create new attitudes and sensations, highlighting the content. Shape brings matter to the fore in a continual play of visibility and transparency. The design is seductive and increases the appeal of the displayed products. During the development phase of the project, ISA carefully analyzed the day-to-day atmosphere in cafes and shops picking out the different moods, sensations and expectations. And then the genius, creativity and talent of Claudio Silvestrin did the rest: a refrigerated counter that is never cold, but rather creates an ambiance where staff and clients can share moments of warmth and cordiality. I Ghiacci speaks just one language, the language of the future. A forward looking project, a range that expresses Isa's philosophy: innovate the thought before the product.



"When I designed I Ghiacci I wanted to give the counter an assertive, strong and dynamic configuration. I believe it deserves it. I chose an innovative and futuristic shape so that it will not age. I can imagine it on planes and spaceships that will take us into future skies: they will be more congenial journeys" - Claudio Silvestrin.



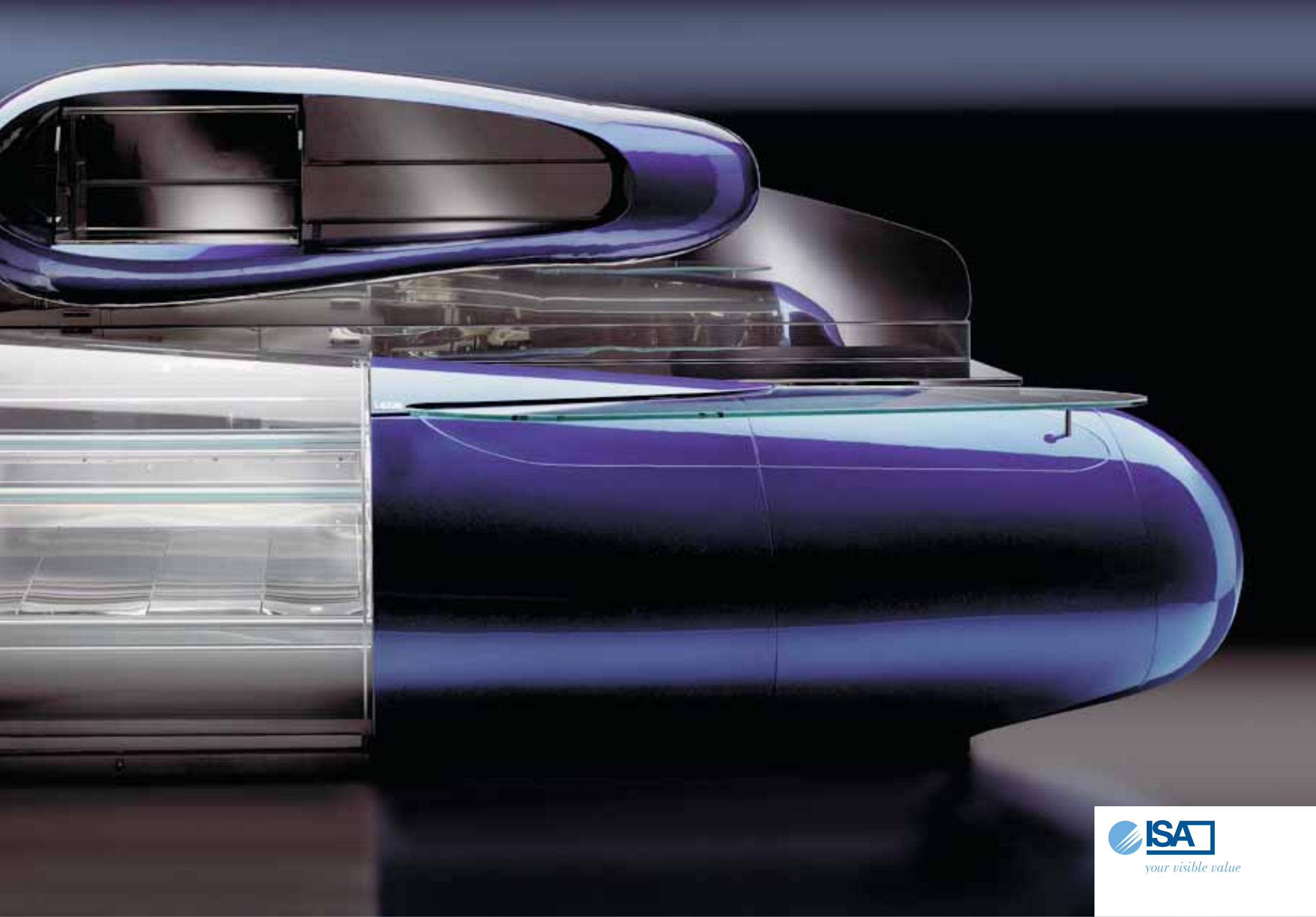

I Ghiacci, beyond the idea of a new system

I Ghiacci reveals the true identity of its setting in accordance with ambient space and light. It has a strong personality of its own that the client can relate to. It breaks and overtakes all the general standard outlines that has been used so far to design shop-fittings projects. I Ghiacci not only enhances the operator's work but emphasizes its image and launches it into the future.









I ghiacci



rational space, total accessibility

Each element was designed rationally: the display case, notable for its transparency and visibility, is unique in its kind, totally openable to ease the cleaning and preparing operations. I Ghiacci gives added value to every operator's activity every day.





i Ghiacci, charming technology

Each line, each curve, was designed as a significant item, part of an extremely innovative and distinguishing project. But the beauty of I Ghiacci can also be found in the technology hidden inside. The search for perfection does not stop at the exterior looks but is part of a constant commitment to make every product unique.

ilhaac



perfection in every detail



The Isa construction philosophy that says nothing is left to chance, that every detail is taken into care, finds its finest expression in this project. The design, the materials, the excellent finishing, the state of the art of technological solutions, the special space-maximising structure that guarantees unequalled display areas, are all elements that clearly identify a unique project presenting new impulses and lifestyles.



i ghiacci

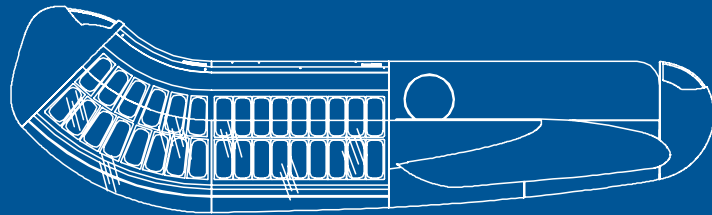

i Ghiacci, pure creativity

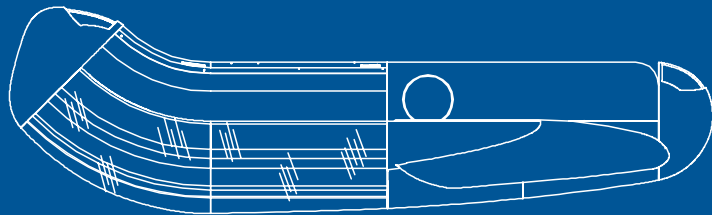
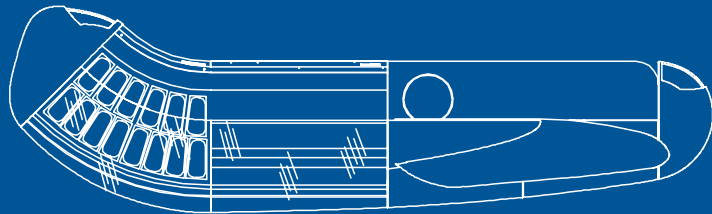

I Ghiacci range is exciting. The design lines draw subtle and seductive attention to the displayed product. The shape accomplishes perfect functionality in combination with incomparable personality.



I ghiacci

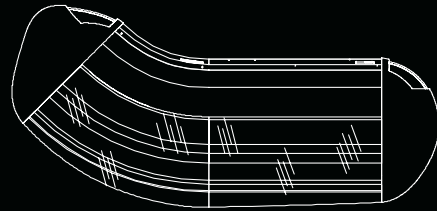
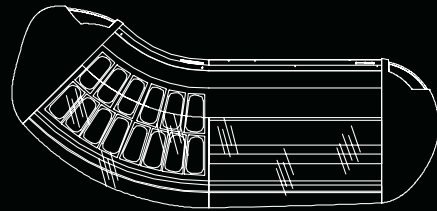
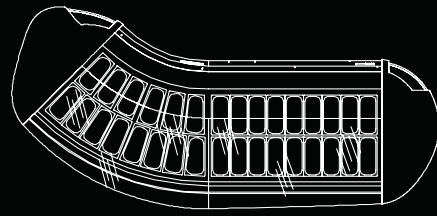

all-out visibility and design

The I Ghiacci design will transport you into the future, thanks to the combination of innovative ideas and unbeatable performance. Isa knows how to create solutions that enamour and stimulate the senses. The transparency and total visibility offered by the display case is seductive, it invites the desire to try and buy. **I Ghiacci, solutions you never thought possible.**



the marvel of technology

Control Unit functions:

ASC (Automatic Set Control)

Varies the automatic set point (reduces energy costs and keeps ice cream at correct temperature).

HACCP

The control unit ensures that the stored products are preserved at temperatures that conform to HACCP standards and gives warning of unfavourable changes.

ICC (Intelligent Check Control)

Identifies and indicates malfunctions.

RCS (Remote Control System)

Controls and monitors remote data.

PDM (Planning Defrost Mode)

Defrosts according to chosen program for a certain period or time.

Pastry display case specifications:

Hermetically sealed compressor

High cooling capacity, low energy costs and low noise output.

Defrosting

Manual defrosting by simple compressor switch off.

Refrigeration

Forced air refrigeration maintains high relative humidity in the fridge compartment.

Ice-cream display case specifications:

Semi-hermetical compressor

High cooling capacity, low energy costs and low noise output.

Defrosting °

Reverse cycle defrosting. Short defrosting cycle to maintain the characteristics of the ice cream.

Dual aeraulic circuit

The dual aeraulic ice cream refrigeration circuit gives maximum temperature stabilization.

DTS (Dual Temperature System)

Offers storage temperature control from -18°C to +6°C, for ice cream in summer and pastries in winter.

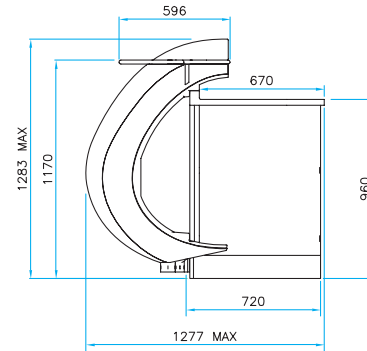
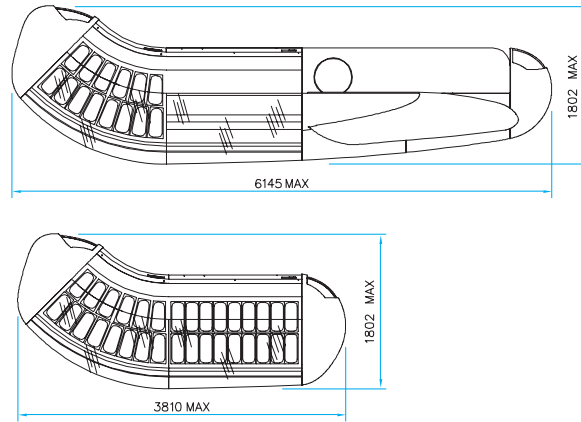
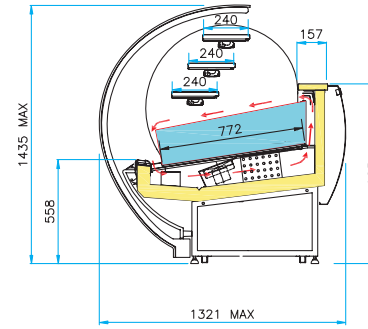
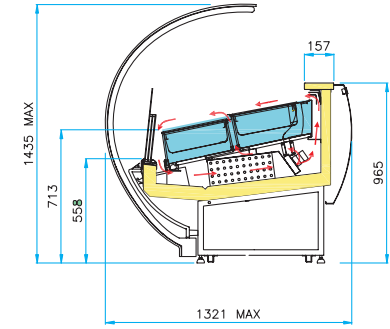

BAR COUNTER

PASTRY DISPLAY CABINETS

ICE-CREAM DISPLAY CABINETS

SPECIFICATIONS			BB 231	VP 170	VP AE 45°	VG 170	VG AE 45°
External dimensions (LxPxH)	mm		2370x1321x1435	1545x1321x1435	/	1545x1321x1435	/
	inch		93,3x52x56,5	60,8x52x56,5	/	60,8x52x56,5	/
Weight (gross/net)	Kg		/	345 / 444	323 / 433	435 / 534	410 / 521
	lb		/	761 / 979	712 / 955	954 / 1177	904 / 1149
Capacity (gross/net: EN441-1)	litri		/	1183/393	1024/346	1158/216	1034/193
	gallon/Us		/	312,5 / 103,8	270,5 / 91,4	305,9 / 57	273,1 / 50,9
Capacità espositiva vaschette litri 5	360x165x120 H		/	/	/	18	/
Capacità espositiva vaschette trapezoidali litri 5	360x185x120 H		/	/	/	/	14
Display surface	m ²		/	1,75	1,6	1,52	1,35
	inch ²		/	2712,5	2480,0	2356,0	2092,5
Loading level	mm		/	230	230	180	180
	inch		/	9,1	9,1	7	7
Refrigerant			R404A	R404A	R404A	R404A	R404A
Compressor	N°		1	1	1	1	1
Refrigeration			Static	Ventilated	Ventilated	Ventilated	Ventilated
Defrosting			Stop Compressor	Stop Compressor	Stop Compressor	Cycle Inversion	Cycle Inversion
Internal condensation system			Air	Air	Air	Air	Air
PERFORMANCE							
Voltage	V / ph / Hz		230 / 1 / 50	230 / 1 / 50	230 / 1 / 50	400 / 3 / 50	400 / 3 / 50
Climatic class:	N° / +°C / % U.R.		/	3 / 25 / 60	3 / 25 / 60	4 / 30 / 55	4 / 30 / 55
Temperature (EN441-5)	°C		+3 / +8	+1 / +10	+1 / +10	-16 / -14	-16 / -14
Electrical input	standard	W	500	1600	1210	3200	2500
	defrosting		/	800	540	4100	3800
Energy consumption (EN441-9)	KWh / 24h		/	32,6	25	59,6	56